

# P&H® *Century 122D*

***Rough Terrain Crane (Cab Down)***  
***22 Ton (20 tonnes) Maximum Capacity***  
***113 Feet (34.4 m) Maximum Tip Height***

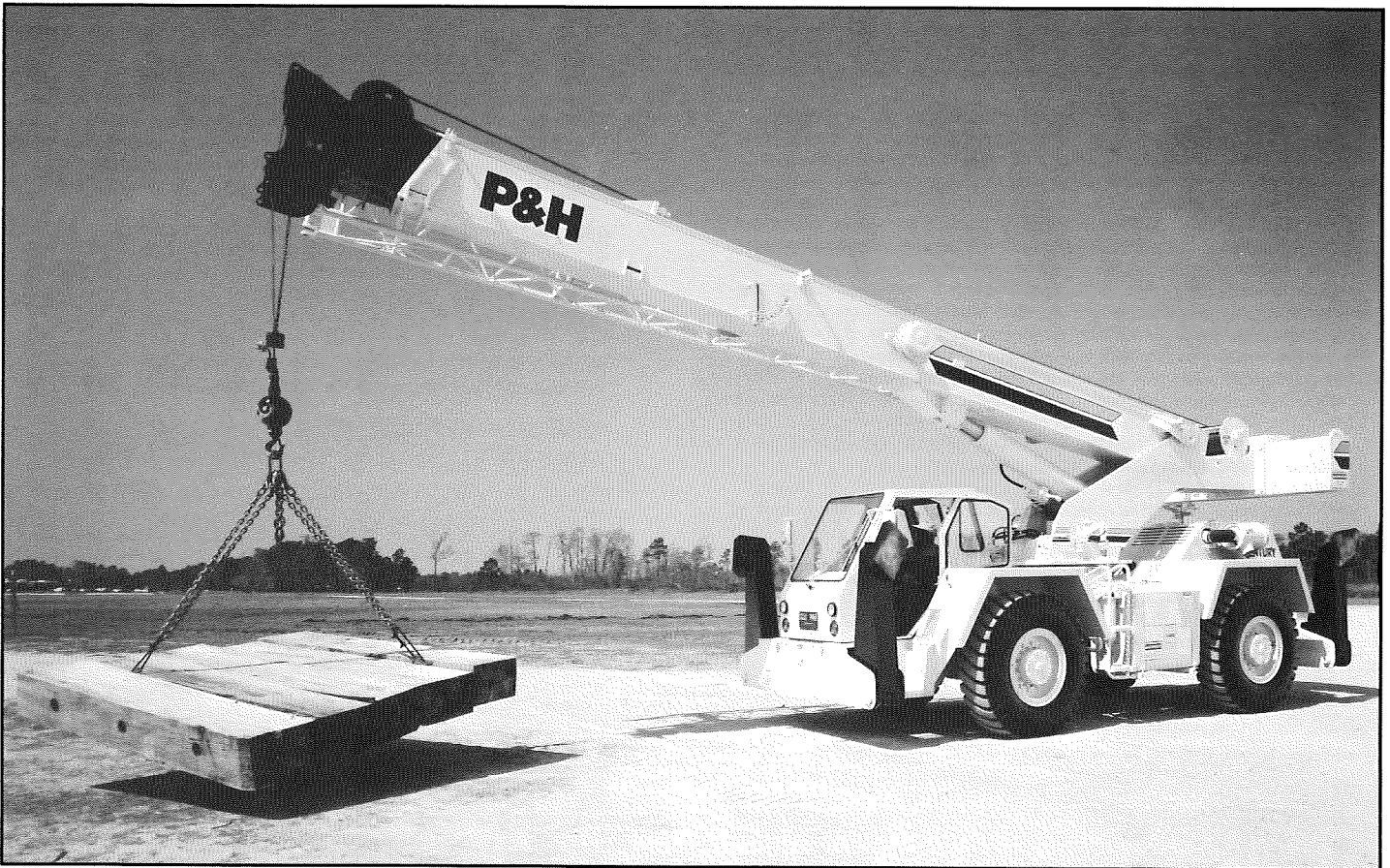

## **Built to Celebrate Over a Century of Quality and Service.**

- **Superior lifting performance** provided by P&H rectangular full depth four-plate boom welded inside and out.
- **Choice of boom attachments** - with lattice extension, telescoping lattice extension, or "A" frame jib (w/ optional 72' boom only) options. Lattice extensions can be offset 22°.
- **Walk-thru cab accessibility** - easiest cab entry in the industry. Spacious cab has convenient placement of controls, lots of leg and elbow room, and full vision of work.
- **A duty-cycle machine** - powerful single-speed P&H winches offer high line speeds and pull. Four pump hydraulic system has optimum flow for fast crane functioning. *No derating of capacities on powered boom or 25-foot lattice extension for bucket work.*

- **Ultra-simple controls** - Direct-acting mechanical controls for all crane operating functions.
- **Heavy-duty electrical system** is built for maximum reliability. Triple-sealed electrical connectors protect against corrosion and vibration.
- **Less downtime** - The industry's most serviceable crane is engineered for maximum reliability of all systems, parts commonality, accessibility, and easy maintenance.
- **Outstanding pick & carry crane** with low center of gravity, excellent machine balance and driving visibility.
- **Takes the bounce out of travel** - exclusive P&H Easy Ride® shock-absorbing device cancels vehicular bouncing motion during travel between jobs.

## **Specifications**



# Specifications

ITEM NO. This P&H crane meets the requirements of ANSI B30.5c-1987. Boom Structure (boom, lattice extension and jib) has been tested per SAE J1063, machine stability tested per SAE J765. LOAD RATINGS shown apply only to machine as manufactured by P&H.

## 1 BASIC MACHINE

### Boom



**Boom:** All boom sections are of full depth rectangular four plate construction, welded inside and out, with adjustable slider pads on top, bottom and sides. All powered sections are single lever controlled. Block type semi-fixed telescope cylinder mounts provide ample capacity to telescope loads. Extension mechanism consists of one hydraulically powered cylinder with holding valve, which extends simultaneously, both the powered "first" section and the cable extended "second" section.

Boom point contains one idler sheave with bronze bushing and four metallic load sheaves with roller bearings. Sheaves are 11.88" (301.7mm) pitch diameter.

**Boom:** 62' (18.90M) three (3) section powered boom, 25' (7.62M) retracted length, 62' (18.90M) extended length, consisting of one base section, one hydraulically powered "first" section, and one cable powered "second" section with boom point.

For performance characteristics, see Chart No.1: Range Diagram 62' Boom and Chart No.3: Lifting Capacities, 62' Boom.

**Cable Extend Mechanism:** As the "first" section is extended, it pulls out the "second" section by a system of twin .875" (22mm) dia. extend cables and 15.75" (400mm) P.D. metallic sheaves with roller bearings. The extend cables are connected to a bracket on the top of the base section, pass around the sheaves which are pinned to the front end of the "first" section, and then connected to a bracket at the rear end of the "second" section to equalize the load on the "extend ropes." The design safety factor is 3.5 to 1. As the powered "first" section is retracted it simultaneously pulls the cable extended "second" section back into the "first" section. The twin retract cables are .50" (13mm) dia. and are connected to brackets on the top of the base section, pass around the 10.31" (262mm) P.D. sheaves with bronze bushings that are pinned inside the rear end of the "first" section, and then connected to a bracket that is mounted inside the rear end of the "second" section.

(For enhanced performance, see Boom Options and Accessories).

### Counterweights (as furnished)

For 62' boom w/o auxiliary hoist - 6000 lbs.(2722kg)  
w/auxiliary hoist - 5500 lbs.(2495kg)  
For 72' boom w/o auxiliary hoist - 7300 lbs.(3311kg)  
w/auxiliary hoist - 6800 lbs.(3084kg)

### Upperstructure

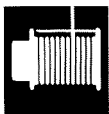

**Main Winch:** P&H model 1080 single speed, mounted on rear of upper frame. Planetary gearing with equal speed power raising and lowering. Infinitely variable controlled speed. Spring applied, hydraulically released load holding multiple disc brake is automatic. Complete with 425' (130M) wire rope.

**Drum:** 10.75" (273mm) P.D. X 16.5" (419mm) wide with 16.75" (425mm) dia. flanges.

**Wire Rope:** 1/2" (13mm) dia. 6x36 extra improved plow steel, with 7x7 I.W.R.C.

(See options, page 4, for spin resistant rope).

See Chart No. 12, Hoist Reeving, for rope capacities and parts of line required.

**Drum Capacity:** 543 ft. (165M) 5 layers.

**Line Pull (Max.):** 10,263 lbs. (4,655kg) 1st layer.

**Line Pull (Permissible - based on strength of wire rope):** 7,600 lbs. (3,448kg) 6x25 cable.

**Line speed Up (max.):** 409 fpm (125M/m) 5th layer.

(See options for Auxiliary Winch)

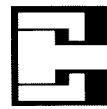

**Boom Hoist:** One 10.0" (254mm) bore X 58.0" (1473 mm) stroke cylinder, double-acting. Hydraulically powered raising and lowering with holding valve. Cylinder has internal accumulator providing a stabilizing "Easy Ride®" when roading machines. Stabilizer is controlled from operator's cab.

**Boom Telescope:** One 6.0" (152mm) bore, double-acting cylinder for powered section. Hydraulically powered extending and retracting with holding valve.

**Hydraulic System:** System utilizes two tandem gear type pumps. One tandem pump, operating at 2650 rpm, provides 44 gpm (167 lpm) to the main and/or auxiliary winches and 44 gpm (167 lpm) to the boom hoist and boom telescope cylinders. A second tandem pump, operating at 2650 rpm, provides 27 gpm (102 lpm) to the swing circuit and brakes, and 27 gpm (102 lpm) for the steering, winch boost and outrigger circuits. Total flow at 2650 engine rpm is 142 gpm (538 lpm). All hydraulic oil is filtered to 7 microns on return to the reservoir. Maximum pressure drop of return filter with clean element and oil at normal operating temperature is 25% of by-pass setting to assure minimum fluid resistance and power loss while protecting seals in cylinders, valves and motors.

The 90 gal. (340 l) reservoir is located on the left side of the carrier. Pumps, valves, cylinders and motors are readily accessible and easy to service. Control valves are four-way, three-position type with low effort spools and pilot-operated relief valves for quick, smooth response. Swing circuit has pressure compensated valve for swing metering control. Cable linkage connects valve to control levers. Hydraulic oil cooler is optional.



**Swing Unit:** Hydraulic motor driving through gear reducer to pinion gear, 360° continuous rotation to 2 rpm.

**Swing Gear:** External cut spur gear 39.667" (100.75cm) P.D. Ring gear dust cover is available (optional).

**Swing Brake:** Fully automatic swing brake, spring applied, hydraulically released, dry disc brake, integral with swing reducer.

**House Lock:** Single position (front) pin-in-hole lock manually engaged with house lock lever. A positive 360° position lock is available (optional).

**Fastening to Lower:** Single row ball bearing integral with swing gear. Welded to carrier frame and bolted to rotating frame. Bearing is protected from dust by labyrinth seal.

**Rotary Manifold:** Sealed rotary swivel for hydraulic hose connections between rotating upper and carrier. Quickly removable from above or below for servicing. Electrical swivel is mounted on top of hydraulic swivel.

### Carrier



**Carrier:** 4x4x4 (Four wheels drive. Four wheels steer) - for rough terrain with limited turning area.

**Frame:** All welded unitized construction assures rigidity and permanent alignment of swing bearing and rotating upper machinery. Fabricated of rectangular structural tubing main frame beams of high strength 46,000 psi (3234kg/sq. cm) minimum yield steel and reinforced with rectangular box cross members of high strength 50,000 psi (3515 kg/sq. cm) minimum yield steel.



**Hydraulic Outriggers:** Four (4) independent arm-type assemblies that hydraulically swing from carrier frame and down to form a stable working platform. Four (4) double-acting hydraulic cylinders equipped with holding valves provide independent movement. Cylinders are actuated by directional joystick control valves operated from cab. Housings and arms are rectangular box members of high strength 80,000 psi (5624 kg/cm) minimum yield steel with four (4) fabricated 14" (35.6cm) sq. floats. Extended spread is 14'-6" (4.42M) from C/L to C/L of floats. Retracted within carrier width of 8'-0" (2.44M).



**Operator's Cab:** Low profile, easy entry environmental cab with two slide-by doors of steel construction is mounted forward of the front axle on the carrier frame. Large safety glass windows are used throughout, providing full view in all directions. Sliding rear window opens for ventilation. Operator's three-way adjustable seat has torsion suspension and seat belt.

**Cab Equipment:** Cab contains all roading and crane function controls. Front console includes gauges for engine water temperature, engine oil pressure, transmission clutch pressure, transmission oil temperature, hydraulic oil temperature, and fuel. Also includes hour meter, voltmeter, audio back-up alarm, windshield wiper, fire extinguisher, electric horn, tachometer, speedometer, rearview mirror and dash light.



**Controls:** In front of operator are foot pedals for service brakes and engine throttle. Far left of steering wheel are console mounted double-acting levers for swing, telescope and outrigger mode. At the right are levers for house lock, auxiliary winch (optional), main winch and boom hoist. Standard console mounted switches for ignition, engine start, windshield wiper, highway lights and travel stabilizer (Easy Ride®). Console has pre-wired, removable modules for ease of service. At operator's right are console mounted levers for outrigger and transmission control, and a hand throttle. Parking brake lever is mounted on inner cab frame.

**Operational Aids:** Dual mechanical boom angle indicators, anti-two block warning indicator with audio-visual warning for main boom, and Krueger Load Moment System - Mark 3E/2. Includes load moment device with audio-visual warning, radius, angle, length, and angle preset. Includes control lever lockouts (magnetic valve shut-off device).



**Steering Options:** (A) Front axle steer - pressure compensated hydrostatic power system fully controlled by steering wheel; (B) Front and rear axle steer - pressure compensated hydrostatic power system fully controlled by steering wheel for front and rear axles. Two wheel, four wheel and crab steer mode selection is controlled by three-position hydraulic valve lever located in cab on side console.

**Front axle:** Steer and drive or non-drive axle driven through differential with planetary in hubs. Axle rigid mounted with power steering.

**Rear Axle:** Steer and drive axle driven through differential with planetary in hubs. Power steering, with optional no-spin differential. Axle is pivot mounted with automatic hydraulic lockout cylinders to prevent oscillation (vertical movement of axle). Total oscillation attainable is 8" (20.3cm).

**Service Brakes:** Hydraulic assisted dual circuit brakes on all four wheels, internal expanding shoe type, actuated by foot pedal in cab.

**Parking Brake:** Mechanical hand lever operated on 10 in. x 3 in. ((254x76.2mm) drum brake on input yoke of front axle.

**Tires:** 14:00X24-20 PR tube type (ML-3)  
See Chart Nos. 15-22 for "On Rubber" lifting capacities.  
Alternate tires and spares available. See Options.

**Miscellaneous Equipment:** Sliding engine hood, tow lugs, hydraulic axle oscillation lockout, highway lights, manual front axle disconnect, and hydraulic pump disconnect.  
Additional accessories listed under Options.



**Power Plant:** (Standard)

Make	Cummins
Model	6BT5.9
Type	Diesel
Cylinders	6
BoreXStroke	4.02X4.72 in. (102X120mm)
Displacement	359 cu.in. 5.88 liters
Cycles	Four
Air Induction	Turbocharged
Starting	12 volt motor Negative Ground
Charging	12 volt alternator, 80 amp

Ratings:	
Gross HP @ rpm	130 @ 2650
Kilowatts @ rpm	97 @ 2650

<b>Accessories:</b>	
Cooling	Liquid recirculating, bypass, pressurized.
Radiator	Tube and fin type, thermostat controlled, with sealed baffle, rapid warm-up.
Starting	12 volt
Electrical	System is 12 volt, negative ground. Wire harnesses have protective braided nylon covering and are individually clamped to framework. Wire harnesses have environmentally sealed Deutsch connectors.
Battery	Reserve capacity 398 minutes. Cold cranking amps at 0°F - 885 amps.
Fuel Tank	50 gal. (189 L) Meets FHWA requirements, (right side between tires).
Air Cleaner	Single stage dry - replaceable element.
Lube oil filter	Replaceable element. Full-flow.
Fuel Filter	Spin-on replaceable element.

**Transmission:** Powershift with high/low range, 6 speeds forward and 6 reverse. Manual front axle disconnect for highway travel. Transmission oil cooler.

Fully sequential transmission is optional.



**Performance:** Standard Powershift Transmission - 6 forward, 6 reverse speeds. Performance in highest and lowest gear based on engine at full load rpm, 42,774 lb. gross vehicle weight, 16:00X24 tires, 62' boom, 6500 lbs. counterweight and good road surface. Maximum grade at 1 mph is approximately 67%.

Low Range Speeds		High Range Speeds	
1st	2.5 mph (4.0 kmph)	1st	6.3 mph (10.1 kmph)
2nd	5.5 mph (8.9 kmph)	2nd	13.0 mph (20.9 kmph)
3rd	12.0 mph (19.3 kmph)	3rd	27.0 mph (43.5 kmph)

(End - BASIC MACHINE)

## OPTIONS

### Boom Options and Accessories

ITEM NO.	
115	72' (21.90M) three (3) section powered boom, 29' (8.8M) retracted length, 72' (21.9M) extended length, consisting of one base section, one hydraulically powered "first" section, and one cable powered "second" section with boom point. Includes Anti-Two Block material.

For performance characteristics, see Chart No.6: Range Diagram 72' Boom and Chart No.8: Lifting Capacities, 72' Boom.

125	<b>25' (7.62M) Lattice Extension:</b> Swing-around tapered lattice structure with single 13.1" (332.7mm) P.D. metallic boom point sheave with bronze bushing. Easily installed from ground level by pivoting from stored position on right side of boom base and pin connected with self-storing pins to boom point. Includes Anti-Two Block material. Offset 2° from boom. For extending reach of boom. Includes Item 145 with new machine.
-----	----------------------------------------------------------------------------------------------------------------------------------------------------------------------------------------------------------------------------------------------------------------------------------------------------------------------------------------------------------------------------------------------------------------------------------------------

For performance characteristics, see Charts Nos. 4, 5, 9, and 10.

135	<b>25'6" to 35'6" (7.8 - 10.8m) Lattice Extension:</b> Swing-around tapered lattice structure with welded four-plate telescopic section and single 13.1" (332.7mm) metallic boom point sheave with bronze bushing. Easily installed from ground level by pivoting from stored position on right side of boom base and pin connected with self-storing pins to boom point. Includes Anti-Two Block material. Offset 2° from boom. For extending reach of boom. Includes Item 150 with new machine.
-----	---------------------------------------------------------------------------------------------------------------------------------------------------------------------------------------------------------------------------------------------------------------------------------------------------------------------------------------------------------------------------------------------------------------------------------------------------------------------------------------------------

For performance characteristics see Chart Nos. 4, 5, 9, and 10.

cont. next page

ITEM NO.	
138	<b>Extension Offset Mechanism:</b> Pivoting links which allow lattice extensions to be offset 22° from main boom. For reach up and over structures.  <i>For Performance characteristics see Charts Nos. 2,5,7 and 10.</i>
140	<b>14' 6" (4.4 m) Jib:</b> Underslung "A" frame structure with single 14.17" (360mm) P.D. metallic boom point sheave with bronze bushing. Easily installed from ground level by pivoting from its stored position on underside of boom base. Pin and pendant connected to boom point. Includes anti-two block material. Offset at 0°, 10° and 20°. For extending reach of boom. Includes Item 155 with new machine. Use with 72' boom only.  <i>For performance characteristics, See chart No. 11.</i>
145	<b>Material for storing 25' (7.62m) extension on right side of boom.</b>
150	<b>Material for storing 25' 6" - 35' 6" (7.8 - 10.8m) extension on right side of boom.</b>
155	<b>Material for storing 14' 6" (4.4m) "A" frame jib under boom.</b>
160	<b>Auxiliary Boom Point Sheave:</b> Single 13.1" (332.7mm) P.D. metallic sheave with bronze bushings, bracket mounted on boom point. Includes anti-two block material. For use with single auxiliary winch line.
205	<b>Auxiliary Winch:</b> Same as main winch. Mounted on rear of revolving frame. Comes with an additional boom point idler sheave.
220	<b>Wire Rope (aux. winch):</b> 1/2" x 360' (13mm x 110m) 6 x 36 extra improved plow steel w/ 7x7 I.W.R.C.
225	<b>Spin Resistant Wire Rope (aux. winch):</b> 1/2" x 360' (13mm x 110m) 8x19 extra improved plow steel w/ 7x7 I.W.R.C.  <i>See Chart no. 12, Hoist Reeving and Wire Rope Capacities.</i>
230	<b>Electrical Drum Turn Indicators</b>
235	<b>22 ton Hook Block:</b> (20 metric ton) 3 sheaves with swivel hook and safety latch, for 1/2" (13mm) wire rope.
240	<b>15 ton Hook Block:</b> (13.6 metric ton) 2 sheaves with swivel hook and safety latch, for 1/2" (13mm) wire rope.
245	<b>10 ton Hook Block:</b> (9.1 metric ton) single sheave with swivel hook and safety latch, for 1/2" (13mm) wire rope.
250	<b>5 ton Ball Hook:</b> (4.5 metric ton) with swivel hook and safety latch, for 1/2" (13mm) wire rope.
255	<b>Cable Spooling Device:</b> main or auxiliary winch.
260	<b>Plumbing and Controls for Auxiliary Winch:</b> (No winch) For later installation of winch.
265	<b>Frame-Mounted Single Speed Winch:</b> 15,000 (6800kg) lb. line pull. (Less cable and hook).
315	<b>Sequential Powershift Transmission:</b> 6 speeds forward, 3 speeds reverse, electrically controlled and operated gear shift. Neutral safety start. Electrically controlled, hydraulically operated front axle disconnect for highway travel.
325	<b>Independent Rear Steer</b>
330	<b>No Spin Axle</b> - rear axle only. Consult factory when quoting.
340	<b>Cold Weather Starting Aid:</b> (measured shot) required below 30°F. (-1°C)
345	<b>Two Battery Start System</b>
350	<b>Override for Axle Lockout</b>
355	<b>Rear Steer Indicator w/Light</b>
365	<b>Engine Condition Warning System</b>
406	<b>Windshield Washer</b>
410	<b>Roof Window Wiper</b>

ITEM NO.	
415	<b>Heater &amp; Defroster:</b> Diesel
420	<b>Heater &amp; Defroster:</b> Propane w/o Tank
422	<b>Heater &amp; Defroster:</b> Hot Water
435	<b>Vandalism Kit:</b> Lexan Glass
440	<b>Tinted Glass</b>
450	<b>Air Conditioner</b>
455	<b>Amber Rotating Beacon:</b> Top of Cab
460	<b>Floodlights:</b> (3)
465	<b>Boom Hoist Foot Pedal</b> (Must order item 665)
510	<b>Tires 16:00x25-24 Ply Tubeless:</b> Earthmover Sure Grip (E-3)
515	<b>Tires 17.5x25-20 Ply Tubeless:</b> Sure Grip Loader (L-2)
520	<b>Tires 20.5x25-20 Ply Tubeless:</b> Sure Grip Lug Wide Base (E2)
525	<b>Tires 20.5x25-20 Ply Tubeless:</b> Super Hard Rock Lug Wide Base (E-3) <i>See "on rubber" lifting Charts nos. 15-22.</i>
530	<b>Spare Tire &amp; Wheel:</b> 14:00x24-20 Ply Tubetype Hard Rock Lug (ML-3)
540	<b>Spare Tire &amp; Wheel:</b> 16:00x25-24 Ply Tubeless Earthmover Sure Grip (E3)
545	<b>Spare Tire &amp; Wheel:</b> 17.5x25-20 Ply Tubeless Sure Grip Loader (L-2)
550	<b>Spare Tire &amp; Wheel:</b> 20.5x25-20 Ply Tubeless Sure Grip Lug Wide Base (E2)
555	<b>Spare Tire &amp; Wheel:</b> 20.5x25-20 Ply Tubeless Super Hard Rock Lug Wide Base (E-3)
605	<b>Positive Swing Lock:</b> 360 Degrees (Required to meet NYC Codes).
610	<b>Slewing Rim Sheet Metal Cover</b>
625	<b>Pintle Hook:</b> (Front or Rear)
650	<b>Tool Box</b>
665	<b>Hydraulic Oil Cooler</b>
815	<b>Special Paint</b>
820	<b>Ship in Prime Paint Only</b>

# Axle Loads

VEHICLE WEIGHTS:	POUNDS			KILOGRAMS		
	GROSS	FRONT	REAR	GROSS	FRONT	REAR
Basic Carrier	13,966	6,332	7,634	6,341	2,875	3,466
Basic Upper	3,927	1,287	2,640	1,783	584	1,199
<b>Standard Equipment</b>						
62 Ft. Boom installed	8,020	9,307	-1,287	3,641	4,225	-584
Roading Stabilizer (Easy Ride®) installed	1,208	706	502	548	320	228
6000 lb. Counterweight installed	6,001	-2,459	8,460	2,725	-1,116	3,841
Main Winch installed	660	-7	667	300	-3	303
Main Winch Wire Rope (.50" dia. x 425')	196	-47	243	89	-21	110
Fenders and Valve Cover installed	577	341	236	262	155	107
6BT 5.9 Cummins Diesel w/R-Shift Transmission	2,389	171	2,218	1,084	77	1,007
14:00 x 24 Tires installed	1,936	968	968	878	439	439
Front Axle installed (Standard)	1,612	1,616	-4	732	734	-2
Rear Axle installed (Standard)	2,183	-37	2,220	991	-17	1,008
Cab installed with Doors	354	441	-87	161	200	-39
<b>Basic Machine</b>	<b>43,029</b>	<b>18,619</b>	<b>24,410</b>	<b>19,535</b>	<b>8,452</b>	<b>11,083</b>
<b>Adjustments for Options</b>						
72 ft. Boom Installed	1,033	2,880	-1,847	469	1,308	-839
<b>Power Plant Options:</b>						
Power-Shift Transmission	63	-3	66	29	-1	30
No-Spin Rear Axle	20	0	20	9	0	9
<b>Tire Options:</b>						
16:00 x 25 Tires installed	1,342	671	671	610	305	305
20.5 x 25 E-2 Tires installed	1,632	816	816	742	371	371
20.5 x 25 E-3 Tires installed	2,000	1,000	1,000	908	454	454
17.5 x 25 L-2 Tires installed	0	0	0	0	0	0
<b>Counterweights:</b>						
5500 lb. CTWT for 62' Boom w/Aux. Winch	-500	204	-704	-227	93	-320
6800 lb. CTWT for 72' Boom with Aux Winch	800	-328	1,128	363	-149	512
7300 lb. CTWT for 72' Boom w/o Aux. Winch	1,300	-533	1,833	590	-242	832
Main & Aux. Winch installed	609	-127	736	276	-58	334
<b>Additions for Options:</b>						
Front Mount Winch installed	406	616	-210	184	279	-95
Floodlights installed	36	37	-1	16	17	-1
Pintle Hook installed - Front	34	54	-20	15	24	-9
Pintle Hook installed - Rear	34	-18	52	15	-8	23
Diesel Heater installed	36	36	0	16	16	0
Propane Heater installed	33	33	0	15	15	0
Hot Water Heater installed	24	15	9	11	7	4
Hydraulic Oil Cooler installed	123	-4	127	56	-2	58
Storage Box installed	70	-20	90	32	-9	41
Aux. Winch Wire Rope (.50" x 360')	166	-72	238	75	-33	108
<b>72 Foot Boom Attachments:</b>						
Aux. Sheave installed	91	272	-181	41	124	-83
25 ft. Lattice Extension	816	1,300	-484	370	590	-220
25-35 ft. Lattice Extension	1,214	1,711	-497	551	776	-225
A-Frame Jib	546	1,126	-580	248	511	-263
10 ton Hook Block 1 Sheave	325	938	-613	148	426	-278
15 ton Hook Block 2 Sheave	336	969	-633	153	440	-287
22 ton Hook Block 3 Sheave	354	1,021	-667	161	464	-303
5 ton Hook	121	355	-234	55	161	-106
<b>62 Foot Boom Attachments:</b>						
Aux. Sheave Installed	91	237	-146	41	107	-66
25 ft. Lattice Extension	816	979	-163	370	444	-74
25-35 ft. Lattice Extension	1,214	1,233	-19	551	560	-9
10 ton Hook Block 1 Sheave	325	810	-485	148	368	-220
15 ton Hook Block 2 Sheaves	336	837	-501	153	380	-227
22 ton Hook Block 3 Sheaves	354	882	-528	161	400	-240
5 ton Hook	121	307	-186	55	140	-85



# Standard 62 Foot Boom Range Diagrams

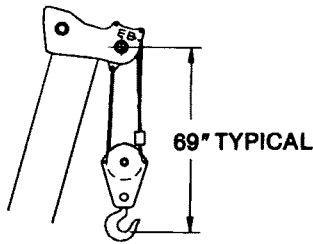
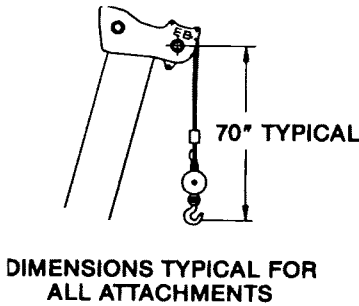

## areas of operation

### ON OUTRIGGERS

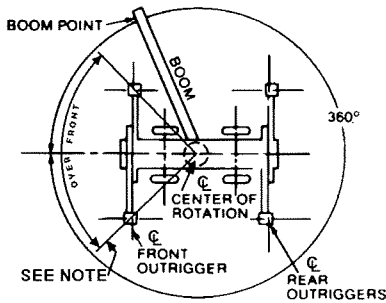

**NOTE**

THESE LINES DETERMINE ANY LIMITING POSITION OF ANY LOAD FOR OPERATION WITHIN WORKING AREAS INDICATED.

### ON TIRES

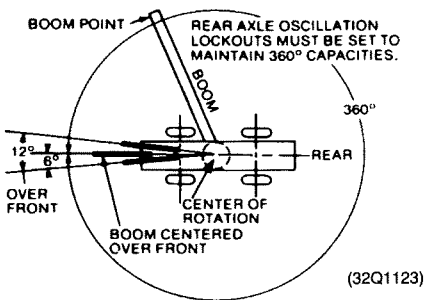

(32Q1123)

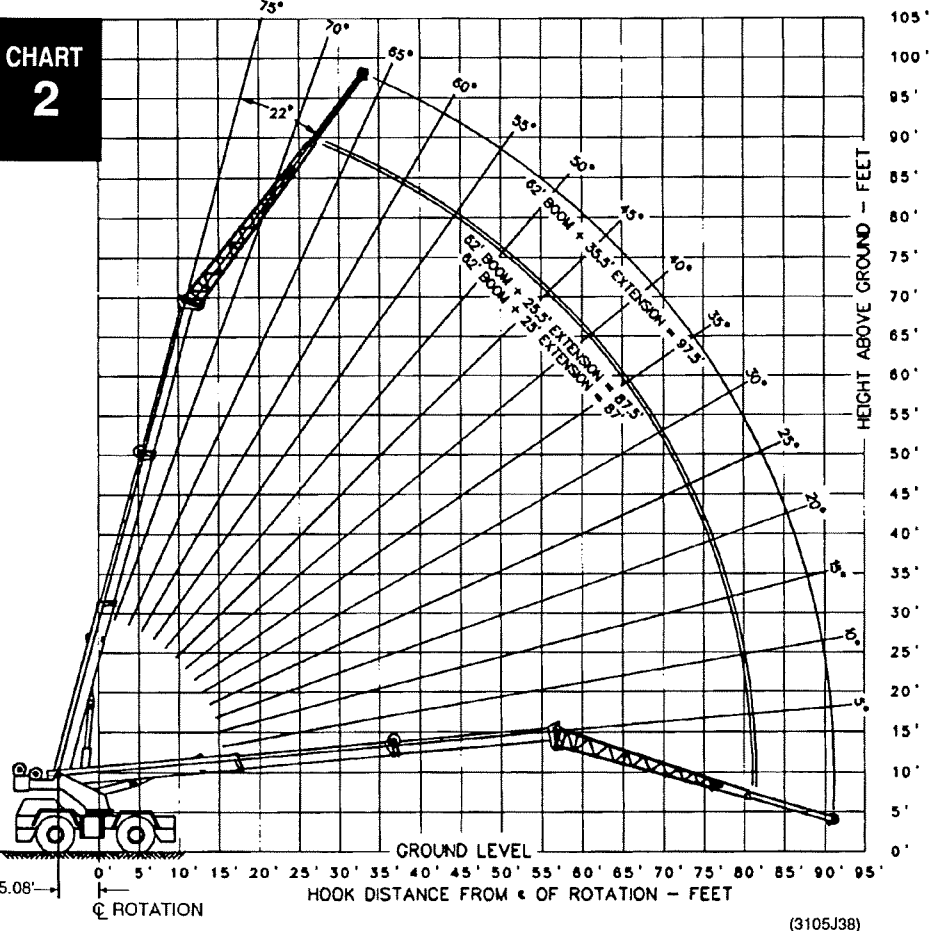
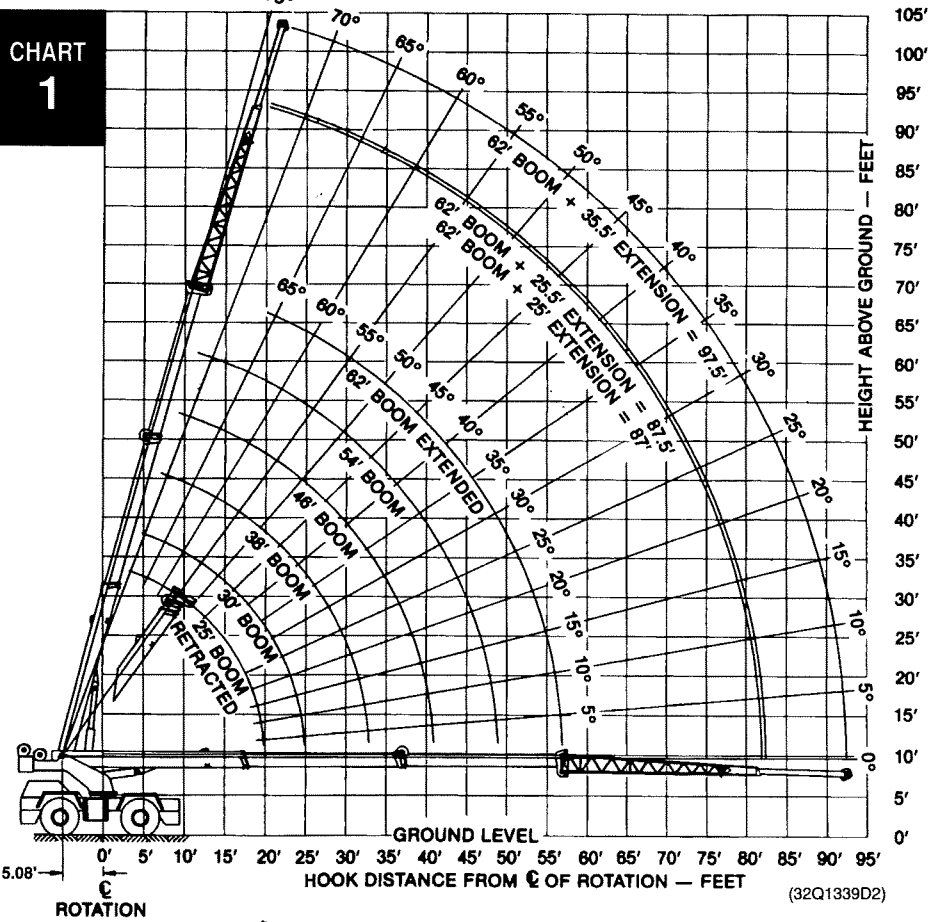

# Standard 62 Foot Powered Boom. Century 122D - Rated Crane Loads in Pounds.

PCSA Class 10-65

CHART 3

POWERED BOOM RATINGS IN POUNDS WITH OUTRIGGERS EXTENDED																			
POWERED BOOM LENGTH																			
OPERATING T. G.T.	25 FT.		30 FT.		38 FT.		46 FT.		54 FT.		62 FT.		OPERATING T. G.T.						
	360°	OVER FRONT	360°	OVER FRONT	360°	OVER FRONT	360°	OVER FRONT	360°	OVER FRONT	360°	OVER FRONT							
10	57	44000	44000	64	41400	41400	70	38700	38700	74	38000	38000					10		
12	52	36000	41300	59	36000	40800	67	36000	38300	72	36000	36300					12		
15	41	28800	34800	52	28800	34800	62	28800	33300	67	28800	31500	72	28800	30000	74	28500	28500	15
20				37	21500	25400	52	21500	25400	60	21500	25400	66	21500	24600	70	21500	23400	20
25							41	14700	19700	53	14700	19700	60	14700	19700	64	14700	19700	25
30							26	10700	15900	44	10700	15900	53	10700	15900	59	10700	15900	30
35										33	8300	13100	45	8300	13100	53	8300	13100	35
40										14	6500	10500	37	6500	10500	47	6500	10500	40
45													25	5200	8500	39	5200	8500	45
50																30	4200	7000	50
55																17	3400	5900	55
60																			60
65																			65

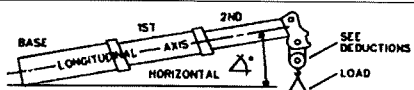

**INFORMATION:**

1. Crane load ratings do not exceed 85% of tipping load.
2. Ratings above the line are based on the machine's hydraulic or structural competence and not on machine stability.
3. Deductions must be made from rated loads for stowed lattice extension, optional attachments, hooks and hookblocks (see Deductions Chart No. 24 on page 12). Weights of slings and all other load handling devices shall be considered part of the load.

4. Crane load ratings with outriggers are based on the outriggers fully extended and set to a distance of 7.25 feet (2.2m) from the longitudinal axis of the carrier to the outrigger float pivot connection with all load removed from carrier wheels.

(32R1079)

CHART 4

LATTICE EXTENSION LOAD RATINGS IN POUNDS WITH OUTRIGGERS EXTENDED											
25 FT. LATTICE EXTENSION				25.5-35.5 FT. LATTICE EXTENSION RETRACTED				25.5-35.5 FT. LATTICE EXTENSION EXTENDED			
OPERATING T. G.T.	FOR ALL BOOM LENGTHS UP TO 87 FT.		OPERATING T. G.T.	FOR ALL BOOM LENGTHS UP TO 87.5 FT.		OPERATING T. G.T.	FOR ALL BOOM LENGTHS UP TO 97.5 FT.		OPERATING T. G.T.	FOR ALL BOOM LENGTHS UP TO 97.5 FT.	
	360°	OVER FRONT		360°	OVER FRONT		360°	OVER FRONT		360°	OVER FRONT
25	73	13000	13000	25	73	13000	13000	25			
30	70	11400	12400	30	70	11100	12000	30	73	9000	9000
35	66	8800	11100	35	66	8600	10700	35	70	8500	8500
40	62	7100	9100	40	63	6800	8900	40	66	7200	8000
45	58	5800	7500	45	59	5500	7200	45	63	5900	7500
50	54	4800	6200	50	55	4500	6000	50	60	4800	6300
55	50	4000	5300	55	50	3700	5000	55	56	4000	5300
60	45	3400	4500	60	45	3100	4200	60	52	3400	4500
65	40	2800	3800	65	40	2500	3600	65	48	2900	3900
70	34	2400	3300	70	34	2100	3000	70	44	2400	3400
75	26	2000	2800	75	27	1700	2600	75	39	2000	2900
80	15	1700	2400	80	17	1400	2200	80	33	1700	2500
								85	26	1400	2100
								90	17	1100	1800

- NOTE:**
1. Stability ratings do not exceed 85% of tipping loads.
  2. When boom is not fully extended, use only boom angles to determine load ratings.
  3. For boom angles not shown, use rating of next lower boom angle.

(32R1079)

**WARNING:**

Deductions from offset extension load ratings must be applied according to Deduction Chart No. 24 on Page 12.

**22° OFFSET**

LATTICE EXTENSION LOAD RATINGS IN POUNDS WITH OUTRIGGERS EXTENDED											
25 FT. LATTICE EXTENSION				25.5-35.5 FT. LATTICE EXTENSION RETRACTED				25.5-35.5 FT. LATTICE EXTENSION EXTENDED			
OPERATING T. G.T.	FOR ALL BOOM LENGTHS UP TO 87 FT.		OPERATING T. G.T.	FOR ALL BOOM LENGTHS UP TO 87.5 FT.		OPERATING T. G.T.	FOR ALL BOOM LENGTHS UP TO 97.5 FT.		OPERATING T. G.T.	FOR ALL BOOM LENGTHS UP TO 97.5 FT.	
	360°	OVER FRONT		360°	OVER FRONT		360°	OVER FRONT		360°	OVER FRONT
30	75	8500	8500	30	75	8200	8200	30			
35	71	8000	8000	35	71	7600	7600	35			
40	68	7500	7500	40	68	7100	7100	40	73	5400	5400
45	64	6200	7000	45	64	6000	6600	45	69	5000	5000
50	60	5100	6600	50	60	4900	6200	50	66	4700	4700
55	55	4300	5600	55	55	4000	5300	55	62	4400	4400
60	50	3600	4700	60	50	3300	4500	60	58	3800	4200
65	45	3000	4000	65	45	2800	3800	65	54	3200	4000
70	38	2500	3500	70	39	2300	3200	70	50	2700	3600
75	30	2100	3000	75	31	1800	2700	75	45	2300	3100
80	18	1700	2500	80	19	1400	2200	80	39	1900	2700
								85	31	1500	2300
								90	20	1200	1900

- NOTE:**
1. Stability ratings do not exceed 85% of tipping loads.
  2. When boom is not fully extended, use only boom angles to determine load ratings.
  3. For boom angles not shown, use rating of next lower boom angle.

(32U2602)

**NOTE:**

For Bucket ratings on 35.5 ft. extension, deduct 20% from load ratings.

Warnings, Definitions and Reeving Chart on page 10 apply to all load rating charts on this page.

# Range Diagrams

## Optional 72 Foot Powered Boom

dzwigi24.pl

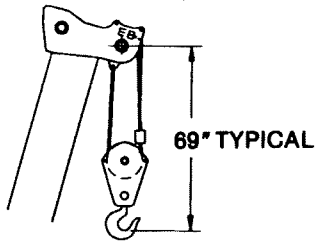
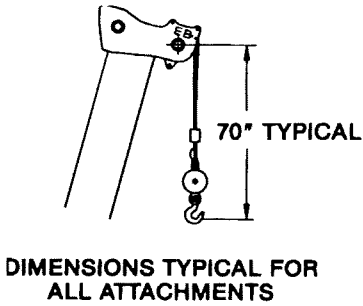

### areas of operation

#### ON OUTRIGGERS

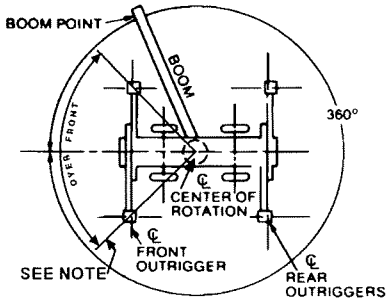

**NOTE**

THESE LINES DETERMINE ANY LIMITING POSITION OF ANY LOAD FOR OPERATION WITHIN WORKING AREAS INDICATED.

#### ON TIRES

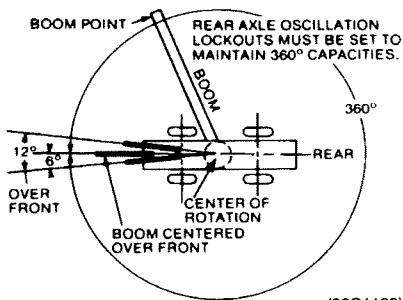

(32Q1123)

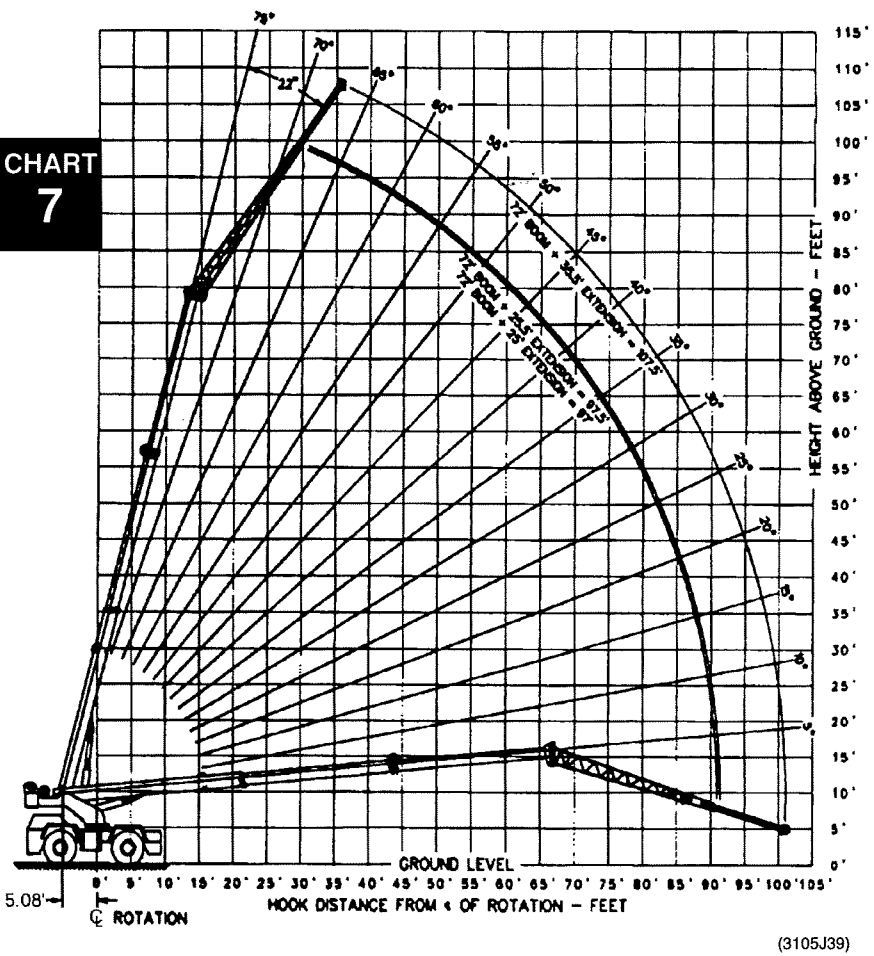
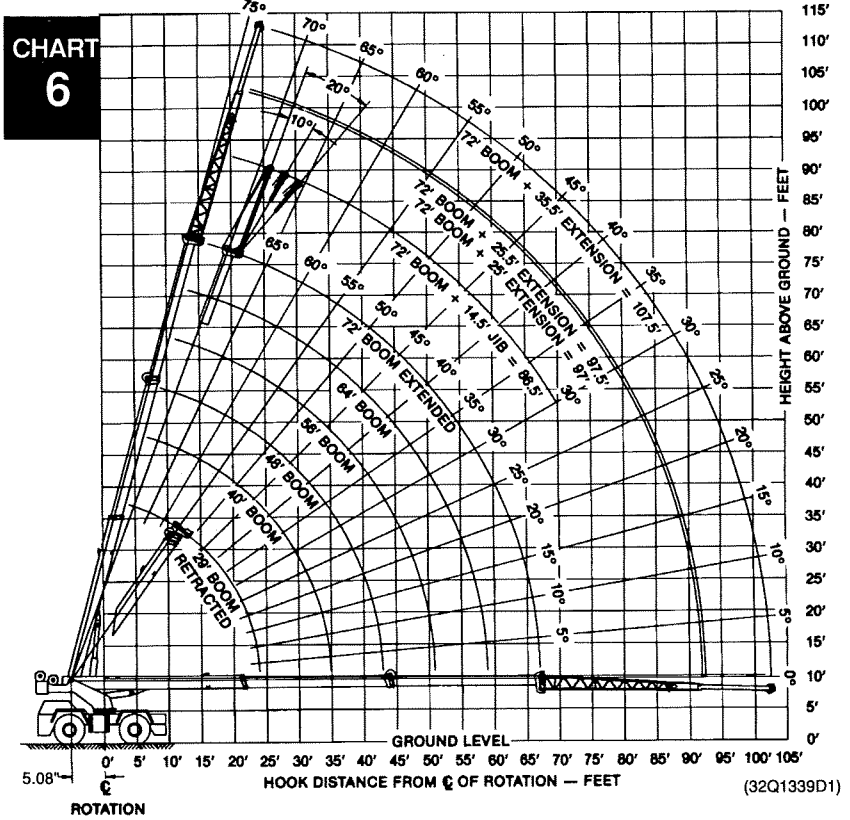



# Optional 72 Foot Powered Boom. Century 122D - Rated Crane Loads in Pounds.

PCSA Class 10-68.

CHART 8

POWERED BOOM RATINGS IN POUNDS WITH OUTRIGGERS EXTENDED																			
POWERED BOOM LENGTH																			
OPERATING T. IN FT.	29 FT.		40 FT.		48 FT.		56 FT.		64 FT.		72 FT.		OPERATING T. IN FT.						
	360°	OVER FRONT	360°	OVER FRONT	360°	OVER FRONT	360°	OVER FRONT	360°	OVER FRONT	360°	OVER FRONT							
10	63	44000	44000	71	38100	38100	75	37400	37400								10		
12	58	36000	40800	68	36000	37500	72	35600	35600								12		
15	51	28800	34800	63	28800	32600	68	28800	30800	72	28800	29400	75	27900	27900		15		
20	34	21600	25700	55	21600	25700	62	21600	25400	67	21600	24100	70	21600	23000	73	21600	21700	20
25				45	15700	19800	54	15700	19800	61	15700	19800	65	15700	19800	69	15700	18400	25
30				32	11400	15900	46	11400	15900	54	11400	15900	60	11400	15900	64	11400	15700	30
35							37	8700	13100	47	8700	13100	54	8700	13100	60	8700	13100	35
40							23	6800	11000	39	6800	11000	48	6800	11000	54	6800	11000	40
45										30	5400	8900	42	5400	8900	49	5400	8900	45
50										13	4300	7300	34	4300	7300	43	4300	7300	50
55													23	3500	6100	36	3500	6100	55
60																28	2900	5100	60
65																16	2300	4300	65

(32R1045)

**NOTE: For A-Frame Jib Ratings, see Chart no. 11, page 10.**

**INFORMATION:**

1. Crane load ratings do not exceed 85% of tipping load.
2. Ratings above the line are based on the machine's hydraulic or structural competence and not on machine stability.
3. Deductions must be made from rated loads for stowed lattice extension or jib, optional attachments, hooks and hookblocks (see Deductions Chart No. 25 on page 12). Weights of slings and all other load handling devices shall be considered part of the load.
4. Crane load ratings with outriggers are based on the outriggers fully extended and set to a distance of 7.25 feet (2.2m) from the longitudinal axis of the carrier to the outrigger float pivot connection with all load removed from carrier wheels.

CHART 9

LATTICE EXTENSION LOAD RATINGS IN POUNDS WITH OUTRIGGERS EXTENDED											
OPERATING T. IN FT.	25 FT. LATTICE EXTENSION		25.5-35.5 FT. LATTICE EXTENSION RETRACTED		25.5-35.5 FT. LATTICE EXTENSION EXTENDED		OPERATING T. IN FT.				
	360°	OVER FRONT	360°	OVER FRONT	360°	OVER FRONT					
27	75	13000	13000	27	75	13000	13000	27			
30	73	12100	12300	30	73	11800	11900	30	75	9300	9300
35	70	9300	11100	35	70	9100	10700	35	72	8800	8800
40	66	7400	9600	40	66	7200	9300	40	69	7600	8300
45	63	6000	7800	45	63	5800	7600	45	66	6100	7900
50	59	5000	6500	50	59	4700	6200	50	63	5100	6600
55	56	4100	5500	55	56	3900	5200	55	60	4200	5600
60	52	3400	4600	60	52	3200	4400	60	57	3500	4700
65	47	2900	3900	65	48	2600	3700	65	53	2900	4000
70	43	2400	3400	70	43	2100	3100	70	49	2400	3400
75	38	2000	2900	75	38	1700	2600	75	45	2000	2900
80	32	1600	2500	80	33	1300	2200	80	41	1700	2500
85	25	1300	2100	85	26	1000	1800	85	37	1400	2100
90	15	1000	1800	90	16	1500		90	31	1100	1800
									95	25	1500
									100	16	1300

- NOTE:**
1. Stability ratings do not exceed 85% of tipping loads.
  2. When boom is not fully extended, use only boom angles to determine load ratings.
  3. For boom angles not shown, use rating of next lower boom angle.

(32R1045)

**WARNING:**  
Deductions from offset extension load ratings must be applied according to Deduction Chart No. 25 on Page 12.

LATTICE EXTENSION LOAD RATINGS IN POUNDS WITH OUTRIGGERS EXTENDED											
OPERATING T. IN FT.	25 FT. LATTICE EXTENSION		25.5-35.5 FT. LATTICE EXTENSION RETRACTED		25.5-35.5 FT. LATTICE EXTENSION EXTENDED		OPERATING T. IN FT.				
	360°	OVER FRONT	360°	OVER FRONT	360°	OVER FRONT					
35	74	8200	8200	35	74	7900	7900	35			
40	71	7700	7700	40	71	7400	7400	40	75	5500	5500
45	67	6600	7300	45	67	6300	7000	45	72	5200	5200
50	64	5400	6900	50	64	5200	6600	50	69	4900	4900
55	60	4500	5900	55	60	4200	5600	55	66	4600	4600
60	56	3800	5000	60	56	3500	4700	60	63	4000	4400
65	52	3100	4200	65	52	2900	4000	65	59	3300	4200
70	47	2600	3600	70	47	2400	3300	70	55	2800	3800
75	42	2200	3100	75	42	1900	2800	75	52	2300	3200
80	36	1800	2600	80	36	1500	2300	80	47	1900	2700
85	28	1400	2200	85	29	1100	1900	85	42	1600	2300
90	16	1100	1800	90	18	1500		90	37	1200	2000
									95	30	1600
									100	18	1300

- NOTE:**
1. Stability ratings do not exceed 85% of tipping loads.
  2. When boom is not fully extended, use only boom angles to determine load ratings.
  3. For boom angles not shown, use rating of next lower boom angle.

(32U2603)

**NOTE: For Bucket ratings on 35.5 ft. extension, deduct 20% from load ratings. Warnings, Definitions and Reeving Chart on page 10 apply to all load rating charts on this page.**

## A-Frame Jib Ratings on Optional 72' Boom Only

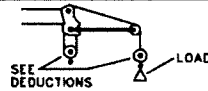
MAXIMUM JIB LOAD RATINGS IN POUNDS WITH OUTRIGGERS EXTENDED			
			
MIN. BOOM ANGLE	JIB ANGLE		
	0°	10°	20°
75°	13000	11200	9500
70°	11400	10300	8500
65°	8100	7500	7000
60°	6100	5700	5500
55°	4700	4500	4300
50°	3800	3600	3500
45°	3100	3000	2900
40°	2600	2500	2500
35°	2200	2100	2100
30°	1900	1800	1800

### CHART 11

#### JIB CAPACITY NOTES:

1. Jib load ratings above the heavy line are based on structural competence of the machine. Ratings below the line are based on stability of the machine and do not exceed 85% of tipping load with fully extended outriggers. Use of outriggers are required when boom is equipped with a jib.
2. For bucket ratings on jib, deduct 20% from maximum jib load ratings.
3. *Warning: Do not lift with jib at boom angles below 30°. Loss of stability below 30° occurs rapidly.*

#### WARNINGS:

1. Loaded boom angle at specified boom lengths give only an approximation of the operating radius. The boom angle before loading should be greater to account for deflections. Do not exceed the operating radius for rated loads.
2. Positioning or operation of powered boom lengths at radii beyond the maximums or minimums shown, is not intended or approved.
3. Positioning or operation of lattice extensions or jib at boom angles beyond the maximums or minimums shown, is not intended or approved.
4. For powered boom lengths not shown, use rating of next longer boom length. For load radii not shown, use rating of next longer radius.
5. Crane load ratings on outriggers are based on freely suspended loads with the machine leveled and standing on a firm, uniform supporting surface. No attempt shall be made to move a load horizontally on the ground in any direction.
6. Practical working loads depend on supporting surface, wind, and other factors affecting stability, hazardous surroundings, experience of personnel, and proper handling, all of which must be taken into account by the operator.
7. The maximum load which may be telescoped is limited by hydraulic pressure, boom angle, and powered boom lubrication. It is safe to attempt to telescope any load within the limits of the load rating chart.

#### DEFINITIONS:

1. Operating radius is the horizontal distance from the center of rotation before loading to the center of the vertical hoist line or tackle with load applied.
2. Loaded boom angle, as shown in the column headed by  $\Delta$ , is the included angle between the horizontal and longitudinal axes of the boom base after lifting rated load at rated radius.

MAIN & AUXILIARY HOIST REEVING 6 X 36 CLASS									
1/2" DIA. WIRE ROPE - BREAKING STRENGTH 26,600 LBS.									
PARTS OF LINE	1	2	3	4	5	6	7	8	9
MAXIMUM LOAD	7600	15200	22800	30400	38000	44000			
MAIN & AUXILIARY HOIST REEVING 8 X 19									
1/2" DIA. WIRE ROPE - BREAKING STRENGTH 23,400 LBS.									
PARTS OF LINE	1	2	3	4	5	6	7	8	9
MAXIMUM LOAD	4650	9300	13950	18600	23250	27900	32550		

### CHART 12

(32R1079)

**NOTE: OPERATION OF THIS EQUIPMENT IN EXCESS OF RATED LOADS AND DISREGARD OF INSTRUCTIONS IS AN UNSAFE PRACTICE AND WILL RESULT IN DENIAL OF WARRANTY CLAIMS.**

### Deductions From Load Ratings When Lifting "OnTires."

CHART 13		62 Foot Boom			
Deductions to be made from Load Ratings in Pounds for 62 ft. Boom					
HOOK BLOCK		Hook Block on Powered Boom Point			
		5 TON	10-22 TON	5 TON WITH AUXILIARY SHEAVE	10-22 TON WITH AUXILIARY SHEAVE
HOOK BLOCK WEIGHT		150	350	250	450
STOWED EXTENSION OR JIB	25 FT. BOOM EXTENSION	300	500	400	600
	25.5 - 35.5 FT. BOOM EXTENSION	300	500	400	600
	14.5 FT. JIB	—	—	—	—
NOTE: LOAD DEDUCTIONS APPLY ONLY TO P&H SUPPLIED EQUIPMENT (32U2699)					

CHART 14		72 Foot Boom			
Deductions to be made from Load Ratings in Pounds for 72 ft. Boom					
HOOK BLOCK		Hook Block on Powered Boom Point			
		5 TON	10-22 TON	5 TON WITH AUXILIARY SHEAVE	10-22 TON WITH AUXILIARY SHEAVE
HOOK BLOCK WEIGHT		150	350	250	450
STOWED EXTENSION OR JIB	25 FT. BOOM EXTENSION	450	650	550	750
	25.5 - 35.5 FT. BOOM EXTENSION	500	700	600	800
	14.5 FT. JIB	500	700	600	800
NOTE: LOAD DEDUCTIONS APPLY ONLY TO P&H SUPPLIED EQUIPMENT (32U2870)					

## "On Tires" Standard 62 Ft. Powered Boom

CHART 15					CHART 16					CHART 17					CHART 18				
17.50 x 25 - 20 PLY TIRES					14:00 X 24-20 PLY TIRES					16:00 X 25-24 PLY TIRES					20.50 X 25-20 PLY TIRES				
STATIONARY		PICK & CARRY BOOM CENTERED OVER FRONT			STATIONARY		PICK & CARRY BOOM CENTERED OVER FRONT			STATIONARY		PICK & CARRY BOOM CENTERED OVER FRONT			STATIONARY		PICK & CARRY BOOM CENTERED OVER FRONT		
±6° ARC OVER FRONT	360° ARC	CREEP	2 1/2 MPH		±6° ARC OVER FRONT	360° ARC	CREEP	2 1/2 MPH		±6° ARC OVER FRONT	360° ARC	CREEP	2 1/2 MPH		±6° ARC OVER FRONT	360° ARC	CREEP	2 1/2 MPH	
10	29000	20000	24600	18800	10	29000	20900	24500	18800	10	34000	21400	32000	27100	10	33200	22100	28900	20300
12	25200	14800	21300	16200	12	25000	15400	21200	16200	12	27900	15800	27800	23500	12	28000	16300	25100	17500
15	18400	10300	17600	13200	15	18400	10700	17500	13200	15	18900	11000	18900	18900	15	18900	11300	18900	14400
20	11500	6400	11500	9900	20	11500	6700	11500	9900	20	11800	6900	11800	11800	20	11800	7100	11800	10800
25	8000	4400	8000	7700	25	8000	4600	8000	7800	25	8200	4700	8200	8200	25	8300	4900	8300	8300
30	5900	3000	5900	5900	30	5900	3100	5900	5900	30	6000	3300	6000	6000	30	6100	3400	6100	6100
35	4500	2100	4500	4500	35	4500	2200	4500	4500	35	4600	2300	4600	4600	35	4600	2400	4600	4600
40	3400	1400	3400	3400	40	3400	1500	3400	3400	40	3500	1600	3500	3500	40	3500	1700	3500	3500
45	2700	1000	2700	2700	45	2700	1100	2700	2700	45	2800	1100	2800	2800	45	2800	1200	2800	2800
50	2100		2100	2100	50	2100		2100	2100	50	2200		2200	2200	50	2200		2200	2200
55	1600		1600	1600	55	1600		1600	1600	55	1700		1700	1700	55	1700		1600	1700

(32U2704)

(32U2699)

(32U2703)

(32U2701)

## "On Tires" Optional 72 Ft. Powered Boom

CHART 19					CHART 20					CHART 21					CHART 22				
17.50 x 25 - 20 PLY TIRES					14:00 X 24-20 PLY TIRES					16:00 X 25-24 PLY TIRES					20.50 X 25-20 PLY TIRES				
STATIONARY		PICK & CARRY BOOM CENTERED OVER FRONT			STATIONARY		PICK & CARRY BOOM CENTERED OVER FRONT			STATIONARY		PICK & CARRY BOOM CENTERED OVER FRONT			STATIONARY		PICK & CARRY BOOM CENTERED OVER FRONT		
±6° ARC OVER FRONT	360° ARC	CREEP	2 1/2 MPH		±6° ARC OVER FRONT	360° ARC	CREEP	2 1/2 MPH		±6° ARC OVER FRONT	360° ARC	CREEP	2 1/2 MPH		±6° ARC OVER FRONT	360° ARC	CREEP	2 1/2 MPH	
10	29000	22000	24600	18700	10	29000	22600	24500	18800	10	34000	23400	31900	27000	10	33200	24100	28800	20300
12	25200	16300	21300	16100	12	25000	16900	21100	16100	12	29400	17300	27700	23400	12	28700	17800	25000	17400
15	19800	11300	17500	13100	15	19800	11600	17400	13100	15	20200	12000	20200	19300	15	20300	12300	20300	14200
20	12200	6900	12200	9600	20	12200	7200	12200	9600	20	12500	7400	12500	12500	20	12500	7600	12500	10500
25	8500	4700	8500	7500	25	8500	4900	8500	7500	25	8800	5100	8800	8800	25	8800	5200	8800	8200
30	6200	3200	6200	5800	30	6200	3400	6200	5800	30	6400	3500	6400	6400	30	6400	3600	6400	6400
35	4700	2300	4700	4600	35	4700	2400	4700	4600	35	4900	2500	4900	4900	35	4900	2600	4900	4900
40	3600	1500	3600	3600	40	3600	1600	3600	3600	40	3700	1700	3700	3700	40	3700	1800	3700	3700
45	2800	1000	2800	2600	45	2800	1100	2800	2800	45	2900	1200	2900	2900	45	2900	1300	2900	2900
50	2100		2100	2100	50	2100		2100	2100	50	2200		2200	2200	50	2200		2200	2200
55	1600		1600	1600	55	1600		1600	1600	55	1700		1700	1700	55	1700		1700	1700
60	1200		1200	1200	60	1200		1200	1200	60	1300		1300	1300	60	1300		1300	1300

(32U2708)

(32U2870)

(32U2707)

(32U2705)

CHART 23

TIRE INFLATION			
SIZE	STATIC & CREEP	2 1/2 MPH	TRAVEL
14:00 x 24-20 PR	110 PSI	100 PSI	75 PSI
16:00 x 25-24 PR	100 PSI	100 PSI	75 PSI
17.50 x 25-20 PR	95 PSI	85 PSI	60 PSI
20.50 x 25-20 PR	80 PSI	65 PSI	50 PSI

**WARNING: CRANE LOAD RATINGS WITHOUT OUTRIGGERS DEPENDS ON TIRE CAPACITY AND CONDITION OF TIRES, INFLATED PER TABLE.**

### WARNINGS:

- When transporting a load, machine must be on a firm, level surface with mechanical houselock engaged. The load must be centered over front of machine and restrained from swinging. See "Areas of Operation" on pages 6 and 8 for working ranges.
- Crane load ratings on tires apply only when rear axle lockouts are engaged when swinging 360°.
- Do not attempt lifts on tires with jib or extension erected.
- Lift with shortest boom possible for each radius.

### DEFINITIONS:

- Creep is motion for less than 200 feet in a 30 minute period and not exceeding 1 mph.

### INFORMATION:

- Ratings above the heavy lines are based on structural competence and not on machine stability.
- It is recommended that outriggers be extended as far as possible and clear of ground when lifting on tires.
- Stability ratings do not exceed 75% of tipping loads.

dzwigi24.pl



**With 62 ft. Boom**

**With 72 ft. Boom**

CHART 24

DEDUCTIONS TO BE MADE FROM LOAD RATINGS IN POUNDS							
DESCRIPTION		WITHOUT HOOK BLOCK ON BOOM POINT	HOOK BLOCK ON POWERED BOOM POINT				
			5 TON	10-22 TON	5 TON WITH AUXILIARY SHEAVE	10-22 TON WITH AUXILIARY SHEAVE	
HOOK BLOCK WEIGHT		-----	150	350	250	450	
HOISTING LOAD FROM POWERED BOOM	25 FT. LATTICE EXTENSION	STOWED	-----	150	350	250	450
		ERECTED ONLY 5 TON BLOCK	-----	1450	1650	1550	1750
		5 TON BLOCK	-----	1800	2000	1900	2100
		10 TON BLOCK	-----	2300	2500	2400	2600
HOISTING LOAD FROM POWERED BOOM	25.5 FT. LATTICE EXTENSION	STOWED	-----	150	350	250	450
		ERECTED ONLY 5 TON BLOCK	-----	2250	2450	2350	2550
		5 TON BLOCK	-----	2600	2800	2700	2900
		10 TON BLOCK	-----	3100	3300	3200	3400
HOISTING LOAD FROM POWERED BOOM	35.5 FT. LATTICE EXTENSION	ERECTED ONLY 5 TON BLOCK	-----	2500	2700	2600	2800
		5 TON BLOCK	-----	2900	3100	3000	3200
		10 TON BLOCK	-----	3550	3750	3650	3850
		14.5 FT. JIB	-----	-----	-----	-----	-----
HOISTING LOAD FROM EXTENSION OR JIB	25 FT. LATTICE EXTENSION	5 TON BLOCK	150	250	350	300	400
		10 TON BLOCK	350	450	550	500	600
	25.5 FT. LATTICE EXTENSION	5 TON BLOCK	150	250	350	300	400
		10 TON BLOCK	350	450	550	500	600
35.5 FT. LATTICE EXTENSION	5 TON BLOCK	150	250	350	250	400	
	10 TON BLOCK	350	450	550	450	600	
14.5 FT. JIB	-----	-----	-----	-----	-----	-----	

CHART 25

DEDUCTIONS TO BE MADE FROM LOAD RATINGS IN POUNDS							
DESCRIPTION		WITHOUT HOOK BLOCK ON BOOM POINT	HOOK BLOCK ON POWERED BOOM POINT				
			5 TON	10-22 TON	5 TON WITH AUXILIARY SHEAVE	10-22 TON WITH AUXILIARY SHEAVE	
HOOK BLOCK WEIGHT		-----	150	350	250	450	
HOISTING LOAD FROM POWERED BOOM	25 FT. LATTICE EXTENSION	STOWED	-----	350	550	450	550
		ERECTED ONLY 5 TON BLOCK	-----	1450	1650	1550	1750
		5 TON BLOCK	-----	1800	2000	1900	2100
		10 TON BLOCK	-----	2300	2500	2400	2600
HOISTING LOAD FROM POWERED BOOM	25.5 FT. LATTICE EXTENSION	STOWED	-----	300	500	400	600
		ERECTED ONLY 5 TON BLOCK	-----	2250	2450	2350	2550
		5 TON BLOCK	-----	2600	2800	2700	2900
		10 TON BLOCK	-----	3100	3300	3200	3400
HOISTING LOAD FROM POWERED BOOM	35.5 FT. LATTICE EXTENSION	ERECTED ONLY 5 TON BLOCK	-----	2500	2700	2600	2800
		5 TON BLOCK	-----	2900	3100	3000	3200
		10 TON BLOCK	-----	3550	3750	3650	3850
		14.5 FT. JIB	-----	-----	-----	-----	-----
HOISTING LOAD FROM EXTENSION OR JIB	25 FT. LATTICE EXTENSION	5 TON BLOCK	150	250	400	300	450
		10 TON BLOCK	350	450	600	500	650
	25.5 FT. LATTICE EXTENSION	5 TON BLOCK	150	250	400	300	450
		10 TON BLOCK	350	450	600	500	650
35.5 FT. LATTICE EXTENSION	5 TON BLOCK	150	250	350	300	400	
	10 TON BLOCK	350	450	550	500	600	
14.5 FT. JIB	-----	-----	-----	-----	-----	-----	

**Dimensions**

DIMENSIONS ARE WITH STANDARD TIRE SIZE - 14.00 x 24  
 WITH 20.5 x 25 TIRES - ADD 1" (25.4mm) TO HEIGHT DIMENSIONS  
 WITH 16.00 x 25 TIRES - ADD 1 - 3/8" (35mm) TO HEIGHT DIMENSIONS

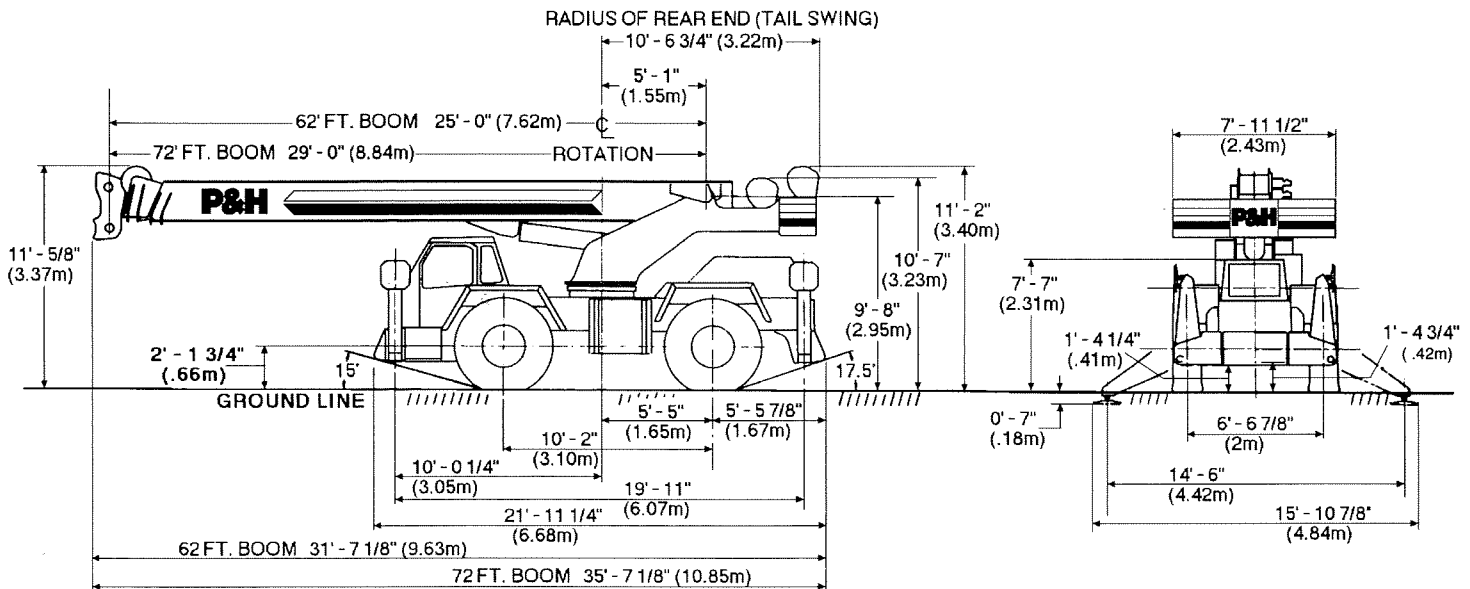

	TIRES			
	14.00 x 24	20.5 x 25	16.00 x 25	17.5 x 25
VEHICLE TURNING DIAMETER - 4 WHEEL STEER CRAMP	31'-6" (9.60m)	35'-6" (10.81m)	38'-10" (11.84m)	38' 7 1/4" (11.77m)
- FRONT AXLE STEER	56' 3" (17.1m)	64'-1" (19.52m)	70'-11" (21.62m)	70' 8" (21.54m)
VEHICLE CLEARANCE DIAMETER - 4 WHEEL STEER CRAMP	37'-11" (11.56m)	41'-3 1/2" (12.58m)	44'-5 1/2" (13.55m)	44' 5 1/2" (13.55m)
- FRONT AXLE STEER	62' 6" (19.1m)	69'-7" (21.20m)	76'-3" (23.22m)	76' 2 1/2" (23.23m)



NOTE: All designs, specifications, and components of the equipment described above are subject to change at the manufacturer's sole discretion at any time and without advance notice. The charts and information printed here are only a guide and may not be complete. They should not be relied upon to operate the crane. The individual load charts and related lifting data on each crane must be understood and govern operation of the crane. Data published herein is informational in nature and shall not be construed to warrant suitability of the machine for any particular purpose as performance may vary with conditions encountered. The only warranty applicable is our standard warranty for this machine.



PPM Cranes, Inc.  
 Manufacturer of P&H mobile cranes.  
 P.O. Box 260002  
 Conway, SC 29526-2602 USA  
 Phone 1-803-349-6900