

GR-120NL

Crane capacity :
12,000 kg at 2.0 m

6-section long boom :
5.3 m - 23.8 m

2-staged bi-fold jib :
3.6 / 5.5 m

Maximum lifting height :
47.1 m (Boom)
64.4 m (Jib)

Maximum load radius :
41.2 m (Boom)
53.9 m (Jib)



MODEL: GR-120NL

SPECIFICATIONS

MAXIMUM CAPACITY	12,000kg at 2.0m
TRAVELLING SPEED(MAX.)	49 km/h
GRADEABILITY (TAN θ)	53%
WEIGHT Gross vehicle mass	14,145 kg
-front axle	7,100 kg
-rear axle	7,045 kg
MIN.TURNING RADIUS	6.5m (2-wheel steering) 3.8 m(4-wheel steering) (at center of extreme outer tire)
BOOM	6-section full length power telescoping boom. Fully retracted length 5.3m Fully extended length 23.8m Extension speed 18.5m in 52s Elevation speed -3° to 82° in 29s
JIB	2-staged boom extension Quadruple offset (5°/25°/45°/60°) type. Single Sheave at jib head. Stored under base boom section. 3.6m and 5.5m
MAIN WINCH	Grooved drum driven by hydraulic axial piston motor through winch speed reducer. Single line pull 17.7 kN {1,800 kgf} Single line speed 125 m/min. (at the 5th layer) Wire rope Spin-resistant type 11.2mm x 137m
AUXILIARY WINCH	Grooved drum driven by hydraulic axial piston motor through winch speed reducer. Single line pull 17.7 kN{1,800 kgf} Single line speed 110 m/min. (at the 3rd layer) Wire rope Spin-resistant type 11.2 mm x 66 m
SWING speed	2.4 min ⁻¹ {rpm}
Tail swing radius	1,600mm
HYDRAULIC SYSTEM	Pumps....2 variable piston pumps for telescoping, elevating and winches. Tandem gear pump for steering, swing and accumulator. Control valves.... Multiple valves actuated by pilot pressure with integral pressure relief valves. Circuit....Equipped with air cooled type oil cooler. Oil pressure appears on AML display for main circuit. Hydraulic oil tank capacity.... approx.172 liters

TADANO Automatic Moment Limiter (Model: AML-C)	Main unit in crane cab gives audible and visual warning of approach to overload. Automatically cuts out crane motions (including swing motion) before overload. With working range (load radius and/or boom angle and/or tip height and/or swing range) limit function. The following functions are displayed. •Moment as percentage •Permissible load •Actual hook load •Boom length •Boom angle •Jib length and jib offset angle (only when jib operation) •Load radius •Potential hook height •Swing angle •Boom position indicator •Number of parts of line of rope •Outriggers position or on-tire indicator •Main hydraulic pressure
OUTRIGGERS	Hydraulically operated H-type outriggers. Each outrigger controlled simultaneously or independently from the cab. Equipped with sight level gauge.
Extended width	Fully 4,700mm Middle 4,300mm 3,500mm 2,500mm Minimum ... 1,640mm Float size (Diameter) ... 350mm
CARRIER	Rear engine, right-hand steering, driving axle 2-way selected type (by manual switch). 4 x 2 front drive 4 x 4 front and rear drive.
ENGINE	Model..... MITSUBISHI 4M50-TLU3B Type 4 cycle, turbo charged and after cooled, 4 cylinder in line, direct injection, water cooled diesel engine. Piston displacement... 4,899 cm ³ Max.output... 129 kW {175 PS} at 2,700 min ⁻¹ {rpm} Max.torque... 530 N·m {54.0 kgf·m} at 1,600 min ⁻¹ {rpm}
TRANSMISSION	Full automatic transmission with torque converter.
STEERING	Hydraulic power steering controlled by steering wheel. 4 steering modes available: 2-wheel front, 2-wheel rear 4-wheel coordinated, 4-wheel crab
SUSPENSION	Semi-elliptic leaf springs with hydraulic lockout device.
TIRES	275 / 80 R22.5, Single x 4
FUEL TANK CAPACITY	189 liters

WORKING RANGE

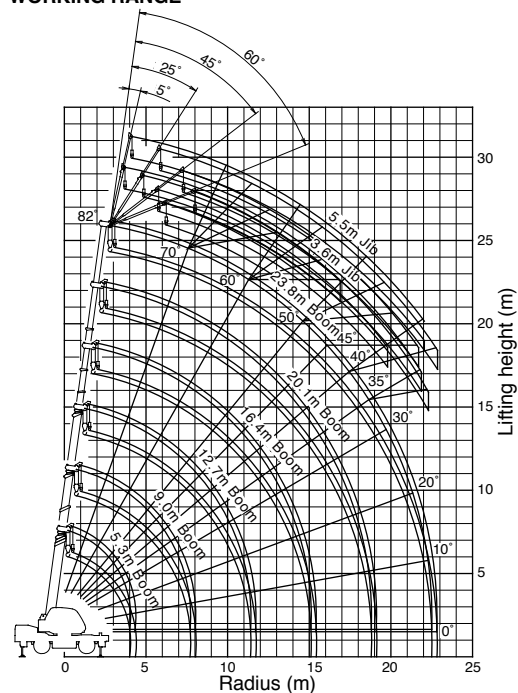

DIMENSION

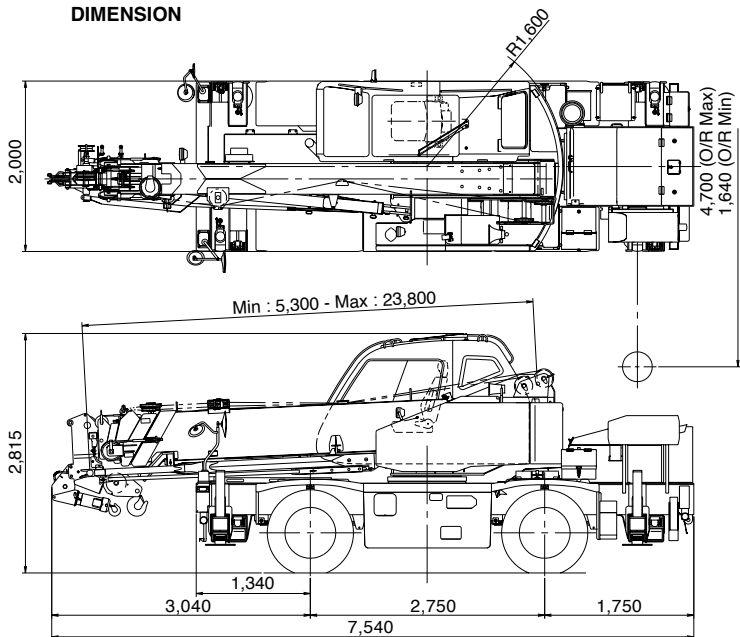

Continuing technical development requires Tadano to retain the right to make specifications, equipment and price changes without notice.

*Some specifications are subject to change



Lifting your dreams

TADANO LTD. (International Division)

4-12, Kamezawa 2-chome, Sumida-ku Tokyo 130-0014, Japan

Phone: 81-3-3621-7750 Fax: 81-3-3621-7785

http://www.tadano-global.com E-mail: tdnihq@tadano.co.jp



GR-120NL

Right hand steering

GENERAL DATA

CRANE CAPACITY		12,000 kg at 2.0 m
BOOM		6-section, 5.3 m - 23.8 m
DIMENSION		
Overall length	approx.	7,540 mm
Overall width	approx.	2,000 mm
Overall height	approx.	2,815 mm
MASS		
Gross vehicle mass	approx.	14,145 kg
-front axle	approx.	7,100 kg
-rear axle	approx.	7,045 kg
PERFORMANCE		
Max. travelling speed	computed	49 km/h
Gradeability(tan θ)	computed	53 %

CRANE SPECIFICATIONS

MODEL

GR-120NL

CAPACITY

12,000 kg at 2.0 m

BOOM

6-section full power partially synchronized telescoping boom of box construction with 4 sheaves at boom head. The synchronization system consists of 2 telescope cylinders, extension cables and retraction cables. Hydraulic cylinders fitted with holding valves.

Fully retracted length..... 5.3 m
 Fully extended length.....23.8 m
 Extension speed.....18.5 m in 52 s

JIB

2-staged boom extension. Four offset (5°/25°/45°/60°) type. Stored under base boom section. Single sheave at jib head.

Length.....3.6 m and 5.5 m

SINGLE TOP (AUXILIARY BOOM SHEAVE)

Single sheave. Mounted to main boom head for single line work.

ELEVATION

By a double-acting hydraulic cylinder, fitted with holding valve.

Elevation speed.....-3° to 82° in 29 s

HOIST - Main winch

Grooved drum driven by hydraulic axial piston motor through winch speed reducer. Power load lowering and hoisting.

Equipped with automatic brake (neutral brake) and counterbalance valve.

Controlled independently of auxiliary winch.

Single line pull17.7 kN {1,800 kgf}
 Single line speed125 m/min. (at the 5th layer)
 Wire rope.....Spin-resistant type
 Diameter x length11.2 mm x 137 m

HOIST—Auxiliary winch

Grooved drum driven by hydraulic axial piston motor through winch speed reducer. Power load lowering and hoisting. Equipped with automatic brake (neutral brake) and counterbalance valve. Controlled independently of main winch.

- Single line pull17.7 kN {1,800 kgf}
- Single line speed110 m/min. (at the 3rd layer)
- Wire ropeSpin-resistant type
- Diameter x length11.2 mm x 66 m

SWING

Hydraulic piston motor driven through planetary swing speed reducer. Continuous 360° full circle swing on ball bearing slew ring. Equipped with spring loaded swing brake.

- Swing speed2.4 min⁻¹{rpm}

HYDRAULIC SYSTEM

- Pumps.....2 variable piston pumps for telescoping, elevating and winches. Tandem gear pump for steering, swing and accumulator.
- Control valves...Multiple valves actuated by pilot pressure with integral pressure relief valves.
- Circuit.....Equipped with air cooled type oil cooler. Oil pressure appears on AML display for main circuit.
- Hydraulic oil tank capacity....
approx. 172 liters
- Filters..... Return line filter

CAB

Both crane and drive operations can be performed from cab mounted on rotating superstructure. One sided one-man type, steel construction cab with safety glass, sliding door access and windows opening at side and rear. 3-way adjustable, shoulder- supportable, cloth-covered operator's suspension seat with armrest.

TADANO Automatic Moment Limiter (Model:AML-C)

Main unit in crane cab gives audible and visual warning of approach to overload. Automatically cuts out crane motions (including swing motion) before overload. With working range (load radius and/or boom angle and/or tip height and/or swing range) limit function. Following functions are displayed.

- Moment as percentage
- Number of parts of line of rope
- Boom angle
- Boom length
- Load radius
- Outriggers position or on-tire indicator
- Actual hook load
- Permissible load
- Boom position indicator
- Potential hook height
- Swing angle
- Main hydraulic oil pressure
- Jib length and jib offset angle
(only when jib operation)

OUTRIGGERS

4-Hydraulically operated H-type outriggers. Each outrigger controlled simultaneously or independently from the cab. Equipped with sight level gauge. Floats mounted integrally with the jacks retract to within vehicle width. All jack cylinders fitted with pilot check valves. Crane operation with different extended length of each outrigger. Equipped with extension width detector for each outrigger.

- Extended width
 - Fully..... 4,700 mm
 - Middle..... 4,300 mm, 3,500 mm, 2,500 mm
 - Minimum..... 1,640 mm
 - Float size (Diameter).. 350 mm

NOTE :

Each crane motion speed is based on unladen conditions.

CARRIER SPECIFICATIONS

SPEC. SHEET NO. GR-120N-2-00222/EX-11

TYPE

Rear engine, right-hand steering, driving axle 2-way selected type (by manual switch).

- 4 x 2 front drive
- 4 x 4 front and rear drive

FRAME

High-tensile steel, all welded box construction.

ENGINE

Model..... MITSUBISHI 4M50-TLU3B

Type..... 4 cycle, turbo charged and after cooled,
4 cylinder in line, direct injection, water cooled diesel engine.

Piston displacement.....4,899 cm³

Bore x stroke..... 114 mm x 120 mm

Max. output 129 kW {175 PS} at 2,700 min⁻¹{rpm}

Max. torque530 N-m {54.0 kgf-m} at
1,600 min⁻¹{rpm}

TRANSMISSION

Electronically controlled full automatic transmission.

Torque converter (with automatic lock up device at forward 1st, 2nd and 3rd of High range) driving full powershift.

High range.....3 forward and 1 reverse speeds.

Low range.....3 forward and 1 reverse speeds.

AXLES

Front..... Full floating type, steering and driving axle.
Conventional differential.

Rear..... Full floating type, steering and driving axle.
Conventional differential.

STEERING

Hydraulic power steering controlled by steering wheel.

4 steering modes available:

- 2-wheel front
- 2-wheel rear
- 4-wheel coordinated
- 4-wheel crab

SUSPENSION

Front.....Semi-elliptic leaf springs with hydraulic lockout device.

Rear.....Semi-elliptic leaf springs with hydraulic lockout device.

BRAKE SYSTEM

Service.....Air over hydraulic disc brakes on all 4 wheels.

Parking.....Spring operated air released brake acting on input shaft of front axle.

Auxiliary... Exhaust brake.

ELECTRIC SYSTEM

24 V DC. 2 batteries of 12 V

FUEL TANK CAPACITY

189 liters

TIRES

Front.....275/80R22.5, Single x 2

Rear.....275/80R22.5, Single x 2

TURN RADIUS

Min. turning radius(at center of extreme outer tire)

2-wheel steering.....6.5 m

4-wheel steering.....3.8 m

EQUIPMENT**STANDARD EQUIPMENT**

Automatic moment limiter (AML-C)
External lamp (AML)
Pendant type over-winding cutout
Winch drum rotation indicator
12 t capacity hook block (4 sheaves)
1.8 t capacity hook block (swivel hook)
Hook safety latch
Hook stowing device
Pilot check valves
Holding valves
Counterbalance valves
Hydraulic pressure relief valves
Swing brake
Swing signal lamp
Boom telescoping foot pedal
Auxiliary winch foot pedal
Outrigger extension width detector
Sight level gauge
Hydraulic oil cooler
Electric windshield wiper and washer
Roof window wiper and washer
Tachometer/Speedometer
Seat belt (Driver's seat)

Air conditioner (Hot water heater type with dehumidification function)
Power window (Right-hand door of the cab)
Cab floor mat
Sun visor (Roof and side)
Neutral position adjustable crane control levers
Automatic drive system
Transmission neutral position engine start
Overshift prevention
Parking braked travel warning
Rear steering lock
Tilt-telescope steering wheel
Back-up alarm
Air cleaner dust indicator
Air dryer
Engine over-run alarm
Hydraulic lockout suspension
Towing eyes - front and rear
Left front view monitor
Emergency steering

OPTIONAL EQUIPMENT

- Power stowing mirror
- Centralized lubricating system(Carrier portion)
- Tire inflation kit

WORKING RANGE

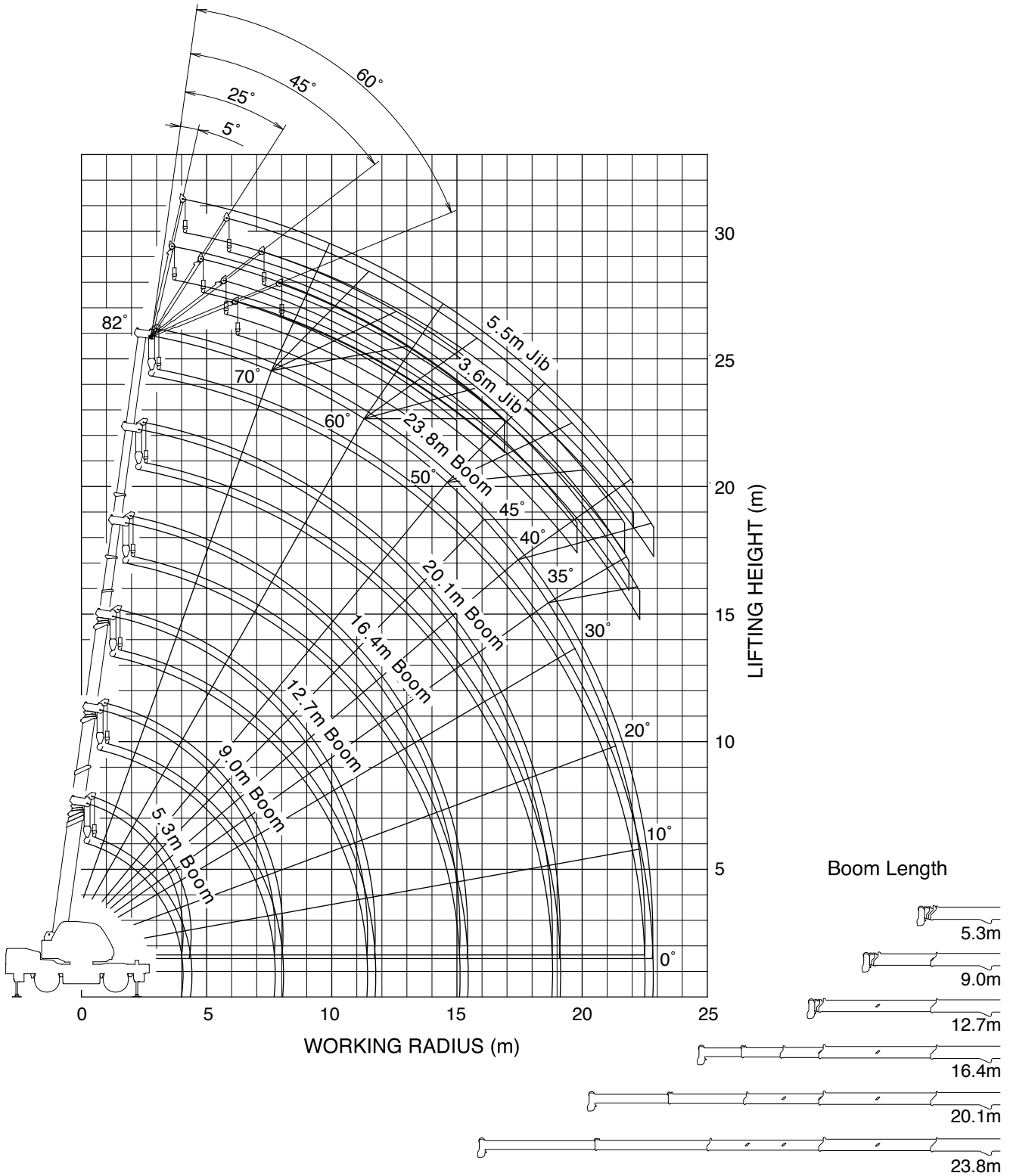

NOTE: 1. The above lifting heights and boom angles are based on a straight (unladen) boom, and allowance should be made for boom deflection obtained under laden conditions.
 2. The above working range is shown on condition with outriggers fully extended.

ON OUTRIGGERS

Unit : kg

		Outriggers fully extended (4.7m) 360° Rotation					
B \ A	5.3 m	9.0 m	12.7 m	16.4 m	20.1 m	23.8 m	
1.0	12,000	6,000					
1.5	12,000	6,000	6,000				
2.0	12,000	6,000	6,000	5,000			
2.5	10,000	6,000	6,000	5,000	4,700		
3.0	8,200	6,000	6,000	5,000	4,700		
3.5	7,000	6,000	6,000	5,000	4,700	3,200	
4.0	6,100	6,000	5,350	4,850	4,250	3,200	
4.5		5,350	4,750	4,350	3,850	3,200	
5.0		4,700	4,250	3,900	3,550	3,000	
5.5		4,150	3,800	3,550	3,300	2,900	
6.0		3,750	3,450	3,200	3,050	2,750	
7.0		3,050	2,850	2,700	2,550	2,350	
8.0		2,700	2,400	2,300	2,200	2,100	
9.0		(7.7m)	2,000	1,950	1,900	1,800	
10.0			1,600	1,700	1,650	1,600	
11.0			1,250	1,500	1,450	1,400	
12.0			1,150	1,250	1,300	1,200	
13.0			(11.4m)	1,050	1,150	1,100	
14.0				900	950	1,000	
15.0				750	850	900	
16.0					700	800	
17.0					600	650	
18.0					500	550	
19.0					400	450	
20.0					(18.7m)	400	
22.0						250	
22.3						230	
D	0°						

A : Boom length

B : Load radius (m)

D : Minimum boom angle for indicated length (no load)

ON OUTRIGGERS

Unit : kg

Outriggers extended to middle (4.3m) Over side						
B \ A	5.3 m	9.0 m	12.7 m	16.4 m	20.1 m	23.8 m
1.0	12,000	6,000				
1.5	12,000	6,000	6,000			
2.0	12,000	6,000	6,000	5,000		
2.5	10,000	6,000	6,000	5,000	4,700	
3.0	8,200	6,000	6,000	5,000	4,700	
3.5	7,000	6,000	6,000	5,000	4,700	3,200
4.0	6,100	6,000	5,350	4,850	4,250	3,200
4.5		5,350	4,750	4,350	3,850	3,200
5.0		4,700	4,250	3,900	3,550	3,000
5.5		4,150	3,800	3,550	3,300	2,900
6.0		3,750	3,450	3,200	3,050	2,750
7.0		3,050	2,850	2,700	2,550	2,350
8.0		2,600	2,350	2,300	2,200	2,100
9.0		(7.7m)	1,800	1,950	1,900	1,800
10.0			1,400	1,650	1,650	1,600
11.0			1,100	1,300	1,450	1,400
12.0			1,000	1,000	1,150	1,200
13.0			(11.4m)	800	950	1,100
14.0				650	750	900
15.0				500	600	750
16.0					500	650
17.0					400	500
18.0					300	430
19.0					250	350
20.0					(18.7m)	250
D	0°					

A : Boom length

B : Load radius (m)

D : Minimum boom angle for indicated length (no load)

ON OUTRIGGERS

Unit : kg

Outriggers extended to middle (3.5 m) Over side						
B \ A	5.3 m	9.0 m	12.7 m	16.4 m	20.1 m	23.8 m
1.0	12,000	6,000				
1.5	12,000	6,000	6,000			
2.0	12,000	6,000	6,000	5,000		
2.5	10,000	6,000	6,000	5,000	4,700	
3.0	8,200	6,000	6,000	5,000	4,700	
3.5	7,000	6,000	6,000	5,000	4,700	3,200
4.0	6,100	6,000	5,350	4,850	4,250	3,200
4.5		5,000	4,750	4,350	3,850	3,200
5.0		4,050	4,050	3,900	3,550	3,000
5.5		3,350	3,300	3,550	3,300	2,900
6.0		2,850	2,800	3,100	3,050	2,750
7.0		2,100	2,050	2,300	2,450	2,350
8.0		1,700	1,450	1,750	1,850	1,950
9.0		(7.7m)	1,050	1,300	1,450	1,550
10.0			750	1,000	1,150	1,250
11.0			550	750	900	1,000
12.0			450	550	700	800
13.0			(11.4m)	400	500	650
14.0				300	400	500
15.0				200	300	350
16.0					200	250
17.0						200
D			0°		21°	36°

A : Boom length

B : Load radius (m)

D : Minimum boom angle for indicated length (no load)

ON OUTRIGGERS

Unit : kg

Outriggers extended to middle (2.5 m) Over side						
A \ B	5.3 m	9.0 m	12.7 m	16.4 m	20.1 m	23.8 m
1.0	12,000	6,000				
1.5	12,000	6,000	6,000			
2.0	12,000	6,000	6,000	5,000		
2.5	8,000	6,000	6,000	5,000	4,700	
3.0	5,700	5,600	5,600	5,000	4,700	
3.5		4,400	4,400	4,500	4,500	3,200
4.0		3,400	3,350	3,600	3,700	3,200
4.5		2,650	2,650	2,900	3,100	3,000
5.0		2,150	2,150	2,350	2,550	2,700
5.5		1,750	1,700	1,950	2,150	2,250
6.0		1,400	1,350	1,650	1,800	1,950
7.0		900	900	1,100	1,250	1,400
8.0		650	550	750	900	1,050
9.0		(7.7m)	300	500	650	800
10.0				300	450	550
11.0					300	350
12.0						250
D		0°	19°	33°	44°	50°

A : Boom length

B : Load radius (m)

D : Minimum boom angle for indicated length (no load)

ON OUTRIGGERS

Unit : kg

Outriggers extended to minimum (1.64 m) Over side						
A \ B	5.3 m	9.0 m	12.7 m	16.4 m	20.1 m	23.8 m
1.0	8,000	6,000				
1.5	7,000	6,000	6,000			
2.0	5,500	5,400	5,500	5,000		
2.5	3,700	3,800	3,550	3,200	3,200	
3.0	2,700	2,850	2,650	2,600	2,600	
3.5	2,100	2,000	2,000	2,050	2,100	2,100
4.0	1,600	1,550	1,500	1,600	1,700	1,750
4.5		1,150	1,100	1,250	1,400	1,450
5.0		850	850	1,000	1,150	1,250
5.5		600	650	800	950	1,050
6.0		450	450	600	750	850
7.0				350	450	550
8.0						350
D	0°	18°	50°	56°	60°	63°

A : Boom length

B : Load radius (m)

D : Minimum boom angle for indicated length (no load)

ON OUTRIGGERS

Unit : kg

Outriggers fully extended (4.7m) 360° rotation																
C	23.8m Boom + 3.6m Jib								23.8m Boom + 5.5m Jib							
	Offset															
	5°		25°		45°		60°		5°		25°		45°		60°	
	R	W	R	W	R	W	R	W	R	W	R	W	R	W	R	W
82	4.1	1,600	5.3	1,200	6.3	1,000	6.6	650	4.5	1,000	6.3	700	7.8	650	8.4	400
80	5.1	1,600	6.2	1,200	7.2	1,000	7.5	650	5.6	1,000	7.3	700	8.8	650	9.3	400
75	7.6	1,550	8.7	1,200	9.4	930	9.6	650	8.3	1,000	9.9	700	11.1	630	11.5	400
70	9.9	1,250	11.0	1,000	11.6	850	11.7	650	10.8	1,000	12.3	650	13.3	580	13.5	400
65	12.1	1,050	13.1	900	13.6	770	13.6	650	13.1	810	14.6	610	15.4	520	15.5	400
60	14.2	900	15.1	800	15.5	700	15.5	650	15.3	690	16.7	550	17.3	480	17.3	400
55	16.1	690	16.9	650	17.3	640			17.4	580	18.6	500	19.1	450		
50	17.8	500	18.5	470	18.8	470			19.2	450	20.3	420	20.7	410		
45	19.5	360	20.0	340	20.2	340			21.0	320	21.9	300	22.1	290		
40	20.9	260	21.4	240					22.5	220	23.2	210				
35	22.2	170	22.6	170												

C : Boom angle (°) R : Load radius (m) W : Rated lifting capacity (kg)

ON OUTRIGGERS

Unit : kg

Outriggers extended to middle (4.3m) Over side																
C	23.8m Boom + 3.6m Jib								23.8m Boom + 5.5m Jib							
	Offset															
	5°		25°		45°		60°		5°		25°		45°		60°	
	R	W	R	W	R	W	R	W	R	W	R	W	R	W	R	W
82	4.1	1,600	5.3	1,200	6.3	1,000	6.6	650	4.5	1,000	6.3	700	7.8	650	8.4	400
80	5.1	1,600	6.2	1,200	7.2	1,000	7.5	650	5.6	1,000	7.3	700	8.8	650	9.3	400
75	7.6	1,550	8.7	1,200	9.4	930	9.6	650	8.3	1,000	9.9	700	11.1	630	11.5	400
70	9.9	1,250	11.0	1,000	11.6	850	11.7	650	10.8	1,000	12.3	650	13.3	580	13.5	400
65	12.1	1,050	13.1	900	13.6	770	13.6	650	13.1	810	14.6	610	15.4	520	15.5	400
60	14.1	800	15.0	740	15.5	700	15.5	650	15.3	690	16.7	550	17.3	480	17.3	400
55	16.1	550	16.8	520	17.2	500			17.4	500	18.6	450	19.1	450		
50	17.8	370	18.5	350	18.8	340			19.2	340	20.2	310	20.6	310		
45	19.4	240	20.0	230	20.2	220			20.9	220	21.7	200	22.0	200		

C : Boom angle (°) R : Load radius (m) W : Rated lifting capacity (kg)

ON OUTRIGGERS

Unit : kg

Outriggers extended to middle (3.5m) Over side																
C	23.8m Boom + 3.6m Jib								23.8m Boom + 5.5m Jib							
	Offset								Offset							
	5°		25°		45°		60°		5°		25°		45°		60°	
	R	W	R	W	R	W	R	W	R	W	R	W	R	W	R	W
82	4.1	1,600	5.3	1,200	6.3	1,000	6.6	650	4.5	1,000	6.3	700	7.8	650	8.4	400
80	5.1	1,600	6.2	1,200	7.2	1,000	7.5	650	5.6	1,000	7.3	700	8.8	650	9.3	400
75	7.6	1,550	8.7	1,200	9.4	930	9.6	650	8.3	1,000	9.9	700	11.1	630	11.5	400
70	9.9	1,250	11.0	1,000	11.6	850	11.7	650	10.8	1,000	12.3	650	13.3	580	13.5	400
65	12.0	800	13.0	700	13.6	700	13.6	650	13.1	660	14.5	660	15.4	450	15.5	400
60	14.0	500	14.9	460	15.4	450	15.5	420	15.1	450	16.4	450	17.2	330	17.3	300
55	15.8	280	16.7	270	17.1	230			17.1	230	18.3	230	18.9	190		

C : Boom angle (°) R : Load radius (m) W : Rated lifting capacity (kg)

ON OUTRIGGERS

Unit : kg

Outriggers extended to middle (2.5m) Over side																
C	23.8m Boom + 3.6m Jib								23.8m Boom + 5.5m Jib							
	Offset								Offset							
	5°		25°		45°		60°		5°		25°		45°		60°	
	R	W	R	W	R	W	R	W	R	W	R	W	R	W	R	W
82	4.1	1,600	5.3	1,200	6.3	1,000	6.6	650	4.5	1,000	6.3	700	7.8	650	8.4	400
75	7.5	1,100	8.5	900	9.4	800	9.6	650	8.3	1,000	9.8	650	11.1	580	11.5	400
70	9.7	570	10.7	500	11.4	450	11.6	400	10.4	500	12.0	400	13.2	350	13.5	300
65	11.8	250	12.7	220	13.4	200	13.4	150	12.6	200						

C : Boom angle (°) R : Load radius (m) W : Rated lifting capacity (kg)

ON OUTRIGGERS

Unit : kg

Outriggers fully extended (4.7m) 360° rotation																
C	20.1m Boom + 3.6m Jib								20.1m Boom + 5.5m Jib							
	Offset															
	5°		25°		45°		60°		5°		25°		45°		60°	
	R	W	R	W	R	W	R	W	R	W	R	W	R	W	R	W
82	3.5	1,600	4.7	1,400	5.6	1,000	6.0	650	3.9	1,000	5.8	1,000	7.1	650	7.8	400
80	4.3	1,600	5.5	1,400	6.4	1,000	6.7	650	4.8	1,000	6.7	1,000	8.0	650	8.6	400
75	6.4	1,600	7.5	1,300	8.3	950	8.5	650	7.1	1,000	8.8	880	9.9	630	10.4	400
70	8.4	1,450	9.4	1,150	10.1	900	10.2	650	9.2	1,000	10.8	790	11.8	580	12.1	400
65	10.3	1,250	11.2	1,000	11.8	860	11.8	650	11.3	960	12.8	720	13.6	550	13.7	400
60	12.1	1,100	12.9	900	13.4	800	13.4	650	13.2	840	14.5	670	15.2	520	15.3	400
55	13.7	900	14.5	750	14.9	700			15.0	730	16.2	600	16.8	490		
50	15.2	660	15.9	600	16.2	540			16.6	560	17.7	480	18.1	450		
45	16.7	480	17.2	440	17.5	410			18.1	400	19.1	360	19.3	320		
40	17.9	340	18.5	310					19.5	270	20.3	240				
35	19.1	220	19.5	210					20.7	170	21.4	160				

C : Boom angle (°) R : Load radius (m) W : Rated lifting capacity (kg)

ON OUTRIGGERS

Unit : kg

Outriggers extended to middle (4.3m) Over side																
C	20.1m Boom + 3.6m Jib								20.1m Boom + 5.5m Jib							
	Offset															
	5°		25°		45°		60°		5°		25°		45°		60°	
	R	W	R	W	R	W	R	W	R	W	R	W	R	W	R	W
82	3.5	1,600	4.7	1,400	5.6	1,000	6.0	650	3.9	1,000	5.8	1,000	7.1	650	7.8	400
80	4.3	1,600	5.5	1,400	6.4	1,000	6.7	650	4.8	1,000	6.7	1,000	8.0	650	8.6	400
75	6.4	1,600	7.5	1,300	8.3	950	8.5	650	7.1	1,000	8.8	880	9.9	630	10.4	400
70	8.4	1,450	9.4	1,150	10.1	900	10.2	650	9.2	1,000	10.8	790	11.8	580	12.1	400
65	10.3	1,250	11.2	1,000	11.8	860	11.8	650	11.3	960	12.8	720	13.6	550	13.7	400
60	12.0	1,000	12.9	900	13.4	800	13.4	650	13.2	840	14.5	670	15.2	520	15.3	400
55	13.7	720	14.4	660	14.9	620			15.0	630	16.2	550	16.8	490		
50	15.2	490	15.9	440	16.2	430			16.6	410	17.7	370	18.1	340		
45	16.6	310	17.2	280	17.4	280			18.1	260	19.0	220	19.2	210		
40	17.8	180	18.4	170					19.5	150						

C : Boom angle (°) R : Load radius (m) W : Rated lifting capacity (kg)

ON OUTRIGGERS

Unit : kg

Outriggers extended to middle (3.5m) Over side																
C	20.1m Boom + 3.6m Jib								20.1m Boom + 5.5m Jib							
	Offset								Offset							
	5°		25°		45°		60°		5°		25°		45°		60°	
	R	W	R	W	R	W	R	W	R	W	R	W	R	W	R	W
82	3.5	1,600	4.7	1,400	5.6	1,000	6.0	650	3.9	1,000	5.8	1,000	7.1	650	7.8	400
80	4.3	1,600	5.5	1,400	6.4	1,000	6.7	650	4.8	1,000	6.7	1,000	8.0	650	8.6	400
75	6.4	1,600	7.5	1,300	8.3	950	8.5	650	7.1	1,000	8.8	880	9.9	630	10.4	400
70	8.4	1,450	9.4	1,150	10.1	900	10.2	650	9.2	1,000	10.8	790	11.8	580	12.1	400
65	10.2	930	11.1	820	11.8	780	11.8	650	11.2	830	12.8	720	13.6	550	13.7	400
60	11.9	590	12.8	510	13.4	470	13.4	470	13.0	500	14.4	420	15.2	360	15.3	400
55	13.6	330	14.4	280	14.8	260			14.8	270	16.1	220	16.7	200		
50	15.1	150														

C : Boom angle (°) R : Load radius (m) W : Rated lifting capacity (kg)

ON OUTRIGGERS

Unit : kg

Outriggers extended to middle (2.5m) Over side																
C	20.1m Boom + 3.6m Jib								20.1m Boom + 5.5m Jib							
	Offset								Offset							
	5°		25°		45°		60°		5°		25°		45°		60°	
	R	W	R	W	R	W	R	W	R	W	R	W	R	W	R	W
82	3.5	1,600	4.7	1,400	5.6	1,000	6.0	650	3.9	1,000	5.8	1,000	7.1	650	7.8	400
75	6.3	1,150	7.5	950	8.3	800	8.5	650	7.1	1,000	8.8	800	9.9	630	10.4	400
70	8.2	610	9.3	530	10.0	480	10.2	480	9.0	520	10.7	440	11.7	380	12.1	370
65	10.1	280	11.1	240	11.7	220	11.8	220	11.0	220						

C : Boom angle (°) R : Load radius (m) W : Rated lifting capacity (kg)

NOTES FOR “ON OUTRIGGERS” TABLE

- Rated lifting capacities based on crane stability are according to ISO 4305.
- Rated lifting capacities shown in the table are based on condition that crane is set on firm level surface. Those above bold lines are based on crane strength and those below, on its stability.
- The mass of the hook (90 kg for 12,000 kg capacity, 25 kg for 1,800 kg capacity), slings and all similarly used load handling devices must be considered as part of the load and must be deducted from the lifting capacities.
- Jib operation should be based on boom angle irrespective of boom length.
The working radius shown above is reference value with jib mounted to 23.8m boom and 20.1m boom.
- For rated lifting capacity of single top, reduce the 65 kg from the relevant boom rated lifting capacity.
Rated lifting capacity of single top should not exceed 1,800 kg.
- High-speed down hoisting should be performed without any load on the hook.
Be sure to operate the levers slowly.
- Standard number of parts of line for each boom length is as shown below.
Load per line should not surpass 1,800 kg for main winch and auxiliary winch.

Boom length (m)	5.3	9.0	12.7	16.4	20.1	23.8	JIB/Single top
No. of parts of line	8	4	4	4	4	4	1

The lifting capacity data stored in the AUTOMATIC MOMENT LIMITER(AML) is based on the standard number of parts of line listed in the chart.

Maximum lifting capacity is restricted by the number of parts of line of AUTOMATIC MOMENT LIMITER(AML).

- The over-side rated lifting capacity depends on outrigger extension. Rated lifting capacity of over-front and over-rear assume fully extended outrigger position. Working area for each outrigger position are given separately and must be followed accordingly during operation.

Outriggers position	Extended to middle (4.3 m)	Extended to middle (3.5 m)	Extended to middle (2.5 m)	Extended to minimum (1.64 m)
Angle a°	45	35	25	15

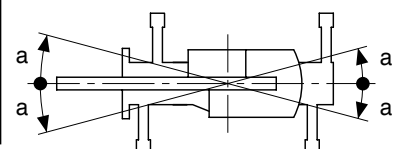

RATED LIFTING CAPACITIES ISO4305

SPEC. SHEET NO. GR-120N-2-00222/EX-11

ON RUBBER (ON TIRES)

Unit : kg

Load radius	Stationary					
	5.3 m Boom		9.0 m Boom		12.7 m Boom	
	Over front	360°	Over front	360°	Over front	360°
1.0 m	3,600	2,800	3,600	2,800		
1.5 m	3,600	2,800	3,600	2,800	3,600	2,800
2.0 m	3,400	2,800	3,400	2,800	3,400	2,800
2.5 m	3,100	2,150	3,100	2,100	3,100	2,050
3.0 m	2,650	1,600	2,600	1,550	2,550	1,500
3.5 m	2,300	1,250	2,200	1,200	2,100	1,100
4.0 m	2,000	900	1,900	800	1,700	700
4.5 m			1,600	500	1,400	400
5.0 m			1,300		1,100	
5.5 m			1,100		950	
6.0 m			900		800	
7.0 m			500		500	

ON RUBBER (ON TIRES)

Unit : kg

Load radius	Creep					
	5.3 m Boom		9.0 m Boom		12.7 m Boom	
	Over front	360°	Over front	360°	Over front	360°
1.0 m	3,200	2,000	3,200	2,000		
1.5 m	3,200	2,000	3,200	2,000	3,200	2,000
2.0 m	3,000	2,000	3,000	2,000	3,000	2,000
2.5 m	2,800	1,550	2,750	1,500	2,650	1,450
3.0 m	2,400	1,100	2,300	1,050	2,200	1,000
3.5 m	2,000	850	1,900	750	1,800	650
4.0 m	1,700	600	1,650	500	1,500	400
4.5 m			1,400	300	1,250	
5.0 m			1,150		1,000	
5.5 m			950		850	
6.0 m			800		700	
7.0 m			450		450	

NOTES FOR "ON RUBBER" TABLES

1. Rated lifting capacities based on crane stability are according to ISO 4305.
2. Rated lifting capacities shown in the table are based on condition that crane is set on firm level surface, with suspension lock applied. Those above bold lines are based on tire capacity and those below, on crane stability. They are based on actual working radii increased by tire deformation and boom deflection.
3. The mass of the hook (90 kg for 12,000 kg capacity, 25 kg for 1,800 kg capacity), slings and all similarly used load handling devices must be considered as part of the load and must be deducted from the lifting capacities.
4. For rated lifting capacity of single top, reduce the 65 kg from the relevant boom rated lifting capacity.
Rated lifting capacity of single top should not exceed 1,800 kg.
5. High-speed down hoisting and on tires lifting with "jib" is not permitted.
Maximum permissible boom length is 12.7 m.
6. CREEP is motion for crane not to travel more than 60 m in any 30 min. period and to travel at the speed of less than 1.6 km/h.
7. During "CREEP" duties travel slowly and keep the lifting load as close to the ground as possible, and especially avoid any abrupt steering, accelerating or braking.
8. Do not operate the crane while carrying the load.
9. Tires should be inflated to their correct air pressure of 900 kPa {9.0 kgf/cm²}.
10. For CREEP operation, set Drive select switch to "4-WHEEL(Lo)" and set gear shift lever to "1".
11. Standard number of parts of line for each boom length is as shown below.
Load per line should not surpass 1,800 kg for main winch and auxiliary winch.

Boom length (m)	5.3	9.0	12.7	Single top
No. of parts of line	4	4	4	1

WORKING AREA

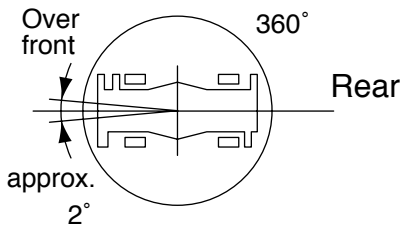

Without outriggers "Over front" operation should be performed within 2 degrees in front of chassis.

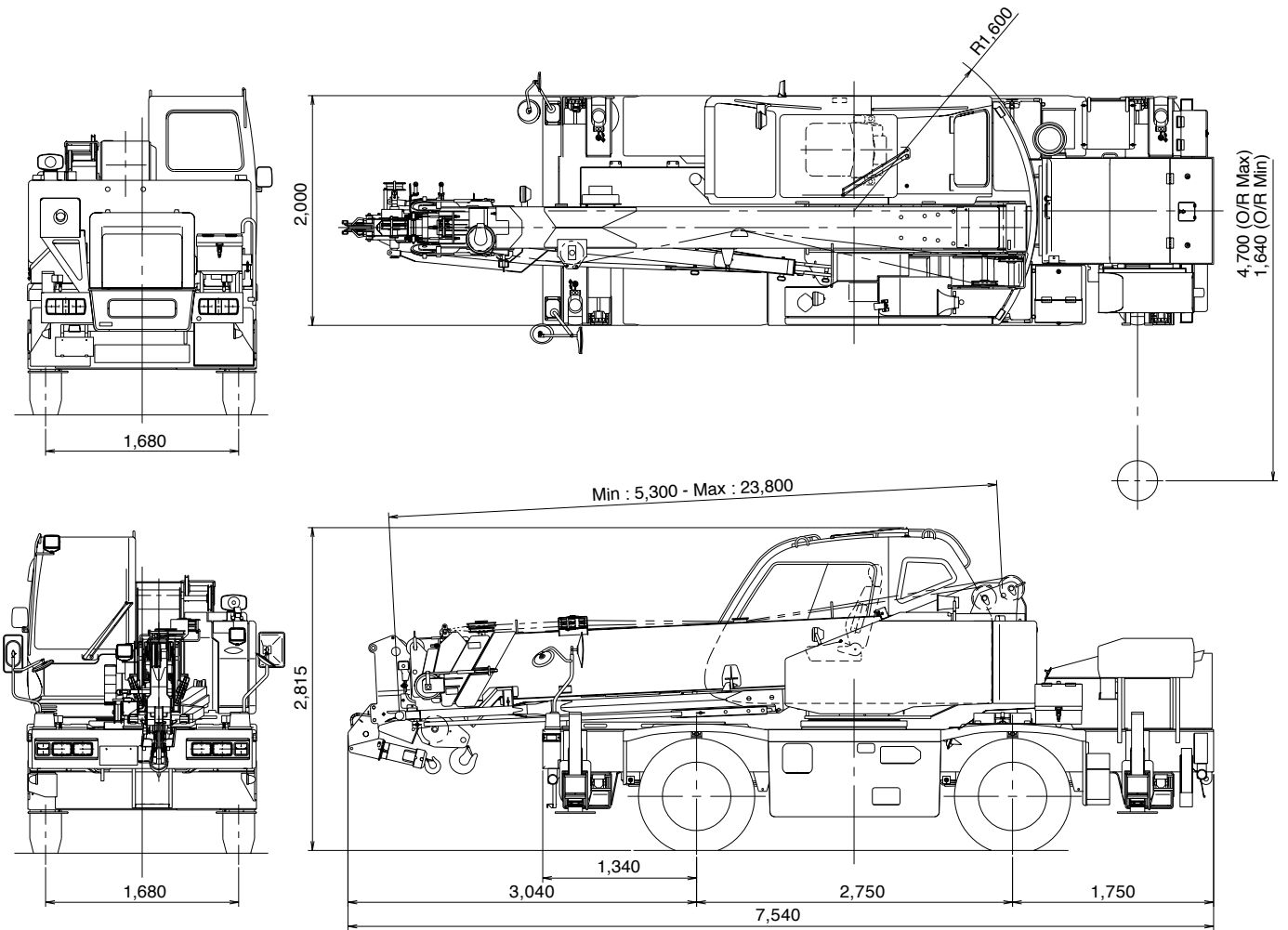

Note : In this external views, a few equipment are included.

Specifications are subject to change without notice.



TADANO

TADANO LTD. (International Division)

4-12, Kamezawa 2-chome,
Sumida-ku, Tokyo 130-0014, Japan

Tel : 81-(0)3-3621-7750

Fax : 81-(0)3-3621-7785

 <http://www.tadano.co.jp/indexe.htm>

 tdnihq@tadano.co.jp

Printed in Japan

GR-120N-2012-06-1