

GTC-300EX

27t Telescopic Boom Crawler Crane

dzwigi24.pl



 TADANO

MANTIS
CRANES

dzwigi24.pl

OPTIONAL EQUIPMENT

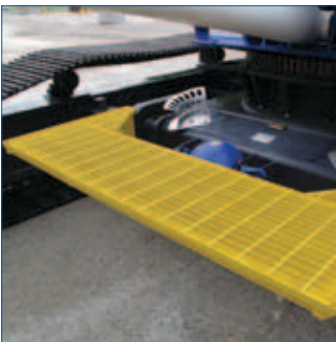

ACCESS WALKWAYS



AUGER KIT AND POLE CLAW



LIGHT BAR AND TOOL CIRCUIT

VERSATILE. POWERFUL. DEPENDABLE.

Tadano Mantis cranes are engineered as VERSATILE, heavy-duty machines. We match massive steel fabrications with diesel engines and state of the art hydraulics to provide a POWERFUL crane that meets the toughest demands in full load pick-and-carry as well as lift applications. MANTIS... the one DEPENDABLE crane that does it all on your jobsite



Pictures may contain optional equipment.

FEATURES

NO OTHER CRANE COMBINES SO MANY VALUABLE FEATURES:

- Pick-and-carry the full crane load chart through 360°.
- Lift and walk...even with tracks retracted.
- Climb steeper grades, thanks to minimized counterweight and low center of gravity.
- Pull through deep mud without bogging down.
- Telescope or lift the boom with a full load on the hook.
- Save time and money on the job due to low clearance height, retract on-the-fly tracks and telescopic boom.
- Independent hydrostatic track drives allow pivot turns and counter rotation.
- Hydraulic tool circuit option powers wide choice of Mantis-approved tools.
- New luxury cab with state-of-the-art operator aids.
- Saves time and money on deployment and shipping with less haul vehicles, less time wasted on boom erection and fewer personnel on the erection crew.

dzwigi24.pl



Large access doors, spacious machinery compartments simplify preventative maintenance and service of the crane.



Conveniently positioned cameras display the winch as well as the blind area directly behind the crane. Full color video display in operator cab is standard equipment.



Spacious cab, adjustable seat, and conveniently located controls are common in all Tadano Mantis Cranes.



State-of-the-art, user friendly rated capacity limiter provides continuous feedback of crane lift and position data.

SPECIFICATIONS dzwigi24.pl

MAXIMUM LIFTING CAPACITY

27.0t at 3m

BOOM

3-section full power synchronized telescoping boom. Synchronized telescoping system consists of one double acting hydraulic cylinder with load holding valves and extension and retraction cables.

- Retracted Length: 10,0 m
- Extended Length: 24,4 m
- Extension Time: 70 s
- Elevating Time: 41 s
- Elevating Angles: -1° to 78°
- Boom Head: Five, 381 mm diameter cast nylon sheaves on heavy-duty roller bearings. Includes three load lifting sheaves and two idler sheaves.
- Auxiliary Boom Head: Quick reeve, single 381 mm diameter high-strength, cast nylon sheave mounted on a heavy-duty roller bearing.
- Hook Block: 27t hook block - Three 406 mm diameter sheaves mounted on heavy duty roller bearings with swivel hook and safety latch.
- Headache Ball: 6,3t ball includes a swivel hook with a safety latch.

WINCHES

Planetary geared single-speed winch includes a bent axis hydraulic motor, multi-disc internal brake and counterbalance valve. Drum rotation indicator is included

- Main Winch
 - Rope Diameter and Length: 14mm x 183m
 - Single line pull: 48,9 kN (first layer)
 - Single line speed: 69,8 m/min (at the 4th layer)
- Auxiliary Winch
 - Rope Diameter and Length: 14mm x 91m
 - Single line pull: 53,4 kN (first layer)
 - Single line speed: 65,2 m/min (at the 4th layer)

TRAVEL

Each side frame contains a pilot controlled, two-speed track drive with hydraulic axial piston motor and parking brake. Travel system provides skid steering and counter rotation.

- Low travel speed: 2,6 km/h
- High travel speed : 4,0 km/h
- Gradeability (unladen): 53%

LOAD MOMENT INDICATOR & ANTI -TWO BLOCK

Standard Rated Capacity Limiter and Anti-Two Block system

- Control function shutdown. Audible and visual warnings
- LCD screen provides a continuous display of working boom length, boom angle, working load radius, tip height, parts-of-line (operator set), machine track configuration, relative load moment, maximum permissible load and actual load.

OPERATOR'S CAB

Fully-enclosed, air conditioned all-steel modular cab with lockable swinging door, acoustical lining, anti-slip floor and tinted safety glass.

- Rear view cameras are appropriately located as are three remote control work lights.
- 2-speed windshield wiper, top glass wiper
- Six-way adjustable fabric seat with headrest, seat belt
- Four, two-way hydraulic armrest mounted joysticks control swing, main winch, auxiliary winch and boom hoist. Foot pedals control the travel, boom extend, and swing service brake functions.
- Seat and armrest termination switches immediately disable all hydraulic functions as the operator rises from the seat or lifts the left hand armrest.

Dash instrumentation: tachometer, voltmeter, oil pressure gauge, temperature gauge, hour meter and fuel gauge. Indicators are provided for crane level, load moment, drum rotation, air filter restriction, hydraulic oil temperature and filter restriction, engine oil pressure and temperature.

ENGINE

- Make/ Model: Cummins QSB 6.7
- Rating: 129 kW (173 hp) @ 2200 RPM

ELECTRICAL SYSTEM

12 VDC

COUNTERWEIGHT

5,220 kg rear counterweight

SWING

Gear motor driving a planetary gear reducer with a shaft mounted pinion, external gear shear ball slew bearing bolted to the superstructure and the carbody allows the superstructure to rotate 360°

- Swing Speed: 0 - 2.2 rpm
- Swing Parking Brake: Spring applied failsafe brake with hydraulic release that is controlled from the operators cab
- Swing Service Brake: Hydraulically applied, controlled through foot actuated pedal
- House Lock System: 2-position, manually pinned

HYDRAULIC SYSTEM

- Hydraulic Pumps: Two high pressure, variable axial piston pumps with load sense and power limiting control for crane functions. One pump for cooling loop
- Directional Valves: Multiple pressure and flow compensated valves with integrated relief valves controlled by hydraulic pilot signals.
- Pump output: 437 liter/min @ 2100 RPM engine speed. 330 bar maximum pressure
- Filtration: 5 micron.

SIDE FRAMES

Two welded steel side frames are paired with a track group. The side frames extend and retract hydraulically and are controlled from the cab.

- Track Rollers: Nine bottom sealed rollers on each track frame Idler: Oil filled, self lubricating with spring type tensioner
- Track Shoes: 760mm 3-bar semi grouser

OPTIONAL EQUIPMENT

- Boom Extension: Lattice type, swing away
 - Length: 6,1 m
 - Head: Two, 183 mm diameter cast nylon sheaves on heavy-duty roller bearings
 - Max. Lifting Height: 29,6 m
- Boom Jib: Lattice type, swing away, stores along boom extension
 - Length: 6,1 m
 - Offset Angles: 15° & 30°
 - Max. Lifting Height: 36,3 m
- Auger Ready Package: Includes hoses, fasteners and stowage bracket assembly mounted to the base section of the boom with a flow capability of 130 liter/min
- Complete Auger Package: Adds a two speed auger motor/gear box and one 1,5m kelly bar to the Auger Ready Package.
- Tool Circuit: Provides 23 liter/min and 45 liter/min at 176 bar through a 15,24m twin hose reel with quick disconnect fittings to operate open center tools.
- Free Fall Hoists: All winches are available in controlled free fall configurations.
- 3-Color Light bar for external load indication
- Pole Claw: Heavy duty pole claw with hydraulic open/close and tilt.
- Access Walkways
- Travel Lever

DIMENSIONS

GTC-300EX

27t Telescopic Boom Crawler Crane

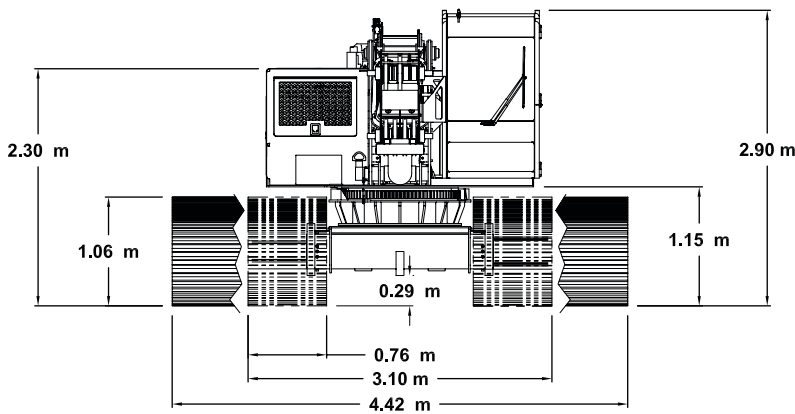
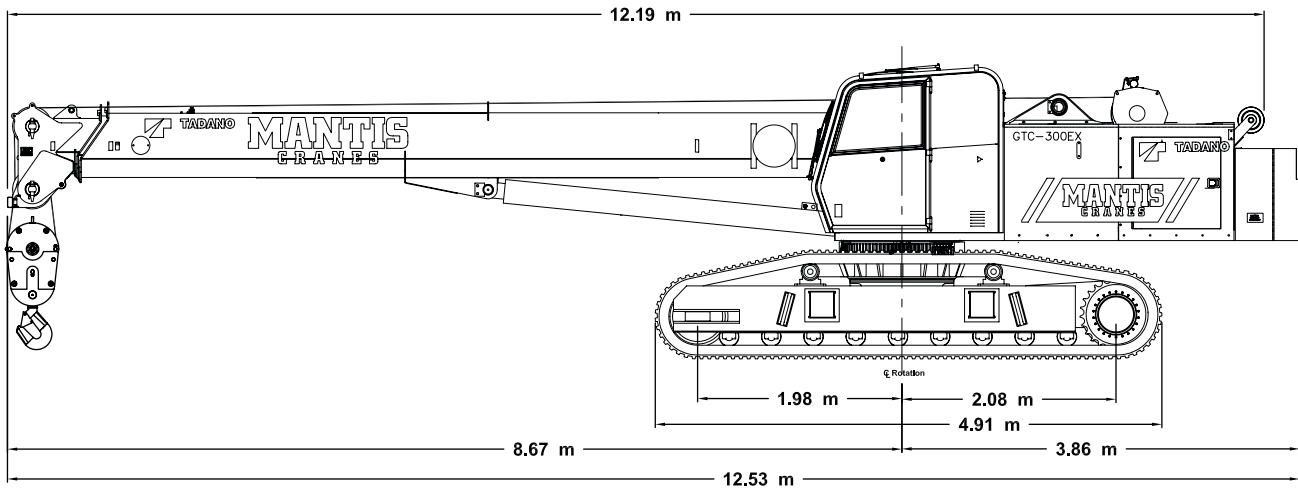

24,4M MAIN BOOM, 6,1M EXTENSION & 6,1M JIB

dzwigi24.pl

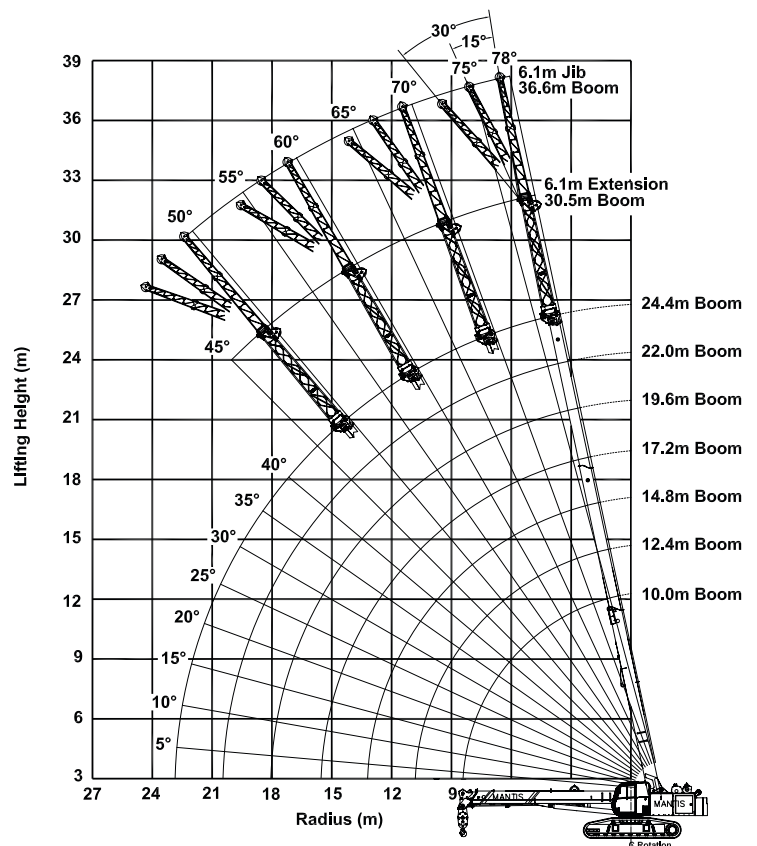

WIDTHS, WEIGHTS, AND GROUND PRESSURES*

Shoe Width	Overall Width		Area	Ground Pressure	Working Weight
	Retracted	Extended			
450 mm	2,59 m	4,11 m	3,72 m ²	0,74 kg/cm ²	27,445 kg
610 mm	2,95 m	4,27 m	4,95 m ²	0,56 kg/cm ²	27,971 kg
760 mm	3,10 m	4,42 m	6,19 m ²	0,46 kg/cm ²	28,495 kg

*Crane equipped with: 24.4m boom, extension, jib, 27t hook block, and 6.3t headache ball

TADANO MANTIS CORPORATION

1705 Columbia Avenue • Franklin, TN 37064 USA • Toll-Free: 1-800-272-3325 • Fax: 615-790-6803 • mantiscranes.com

GTC-300EX 27t Telescopic Boom Crawler Crane

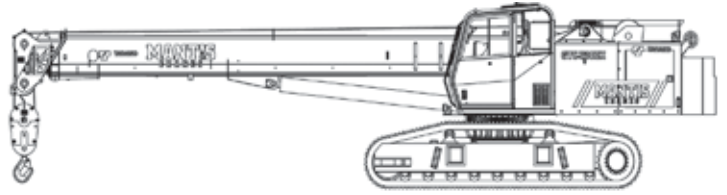

dzwigi24.pl

GTC-400EX 40t Telescopic Boom Crawler Crane

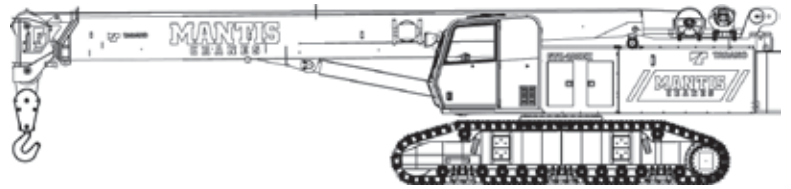

GTC-700EX 70t Telescopic Boom Crawler Crane

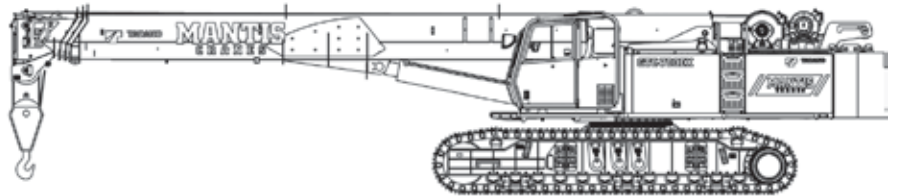

GTC-1000EX 100t Telescopic Boom Crawler Crane

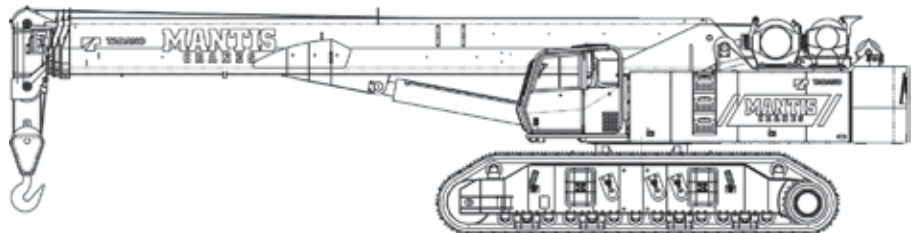

TADANO Ltd., International Division

4-12, Kamezawa 2-chome,
Sumida-Ku, Tokyo 130-0014, Japan

Tel: +81 3 3621 7750

Fax: +81 3 3621 7785

E-mail: tdnihq@tadano.co.jp

www.tadano.co.jp/indexe.html

GTC-300EX

27t Telescopic Boom Crawler Crane

SPECIFICATION SHEET NO. 541-09/11 ISO

GENERAL DATA

CRANE CAPACITY	27t at 3.0m
BOOM	3-section, 10.0 m – 24.4 m
DIMENSION	
Overall Length	12.53 m
Overall Width (tracks extended)	4.42 m
Overall Width (tracks retracted)	3.10 m
Overall Height	2.90 m
MASS	
Gross Vehicle Mass (Standard Equipment Package)	28,495 kg
PERFORMANCE	
Travel Speed	2.6 km/h – 4.0 km/h
Gradability	53%

CRANE SPECIFICATION

MODEL

GTC-300EX

CAPACITY

27t at 3.0m

BOOM

3-section full power synchronized telescoping boom. Synchronized telescoping system consists of double acting hydraulic cylinder with load holding valves and extension and retraction cables.

- Retracted Length: 10.0 m
- Extended Length: 24.4 m
- Elevating Angles: -1° to 78°
- Boom Head: Five, 381 mm diameter cast nylon sheaves on heavy-duty roller bearings. (3 load bearing and 2 lead in sheaves)
- Extension Time: 70 s
- Elevating Time: 41 s

AUXILIARY BOOM HEAD

Quick reeve, single 381 mm diameter high-strength, cast nylon sheave mounted on a heavy-duty roller bearing.

- Hook Block: 27 t hook block - three 406 mm diameter sheaves mounted on heavy duty roller bearings with swivel hook and safety latch.
- Headache Ball: 6.3t ball includes a swivel hook with a safety latch

COUNTERWEIGHT

5,220 kg single piece counterweight can be removed and installed via a pendant attached to the boom

WINCHES

Planetary geared single-speed winch includes a bent axis hydraulic motor, multi-disc internal brake and counterbalance valve. Drum rotation indicator is included (complete winch performance specs on Page 3)

- Main Winch
 - Rope Diameter and Length: 14mm x 183m
 - Single line pull: 49.9 kN (first layer)
 - Single line speed: 69.8 m/min (4th layer)
- Auxiliary Winch
 - Rope Diameter and Length: 14mm x 91m
 - Single line pull: 53.4 kN (first layer)
 - Single line speed: 65.2 m/min (at the 4th layer)

TRAVEL

Each side frame contains a pilot controlled, two-speed track drive with hydraulic axial piston motor and parking brake. Travel system provides skid steering and counter rotation.

- Low travel speed: 2.6km/h
- High travel speed: 4.0 km/h
- Gradeability (unladen): 53%

SWING

Gear motor driving a planetary gear reducer with a shaft mounted pinion, external gear shear ball slew bearing bolted to the superstructure and the carbody allows the superstructure to rotate 360°

- Swing Speed: 0 – 2.2 rpm
- Swing Parking Brake: Spring applied failsafe brake with hydraulic release that is controlled from the operators cab
- Swing Service Brake: Hydraulically applied, controlled through foot actuated pedal
- House Lock System: 2-position, manually pinned

LOAD MOMENT INDICATOR

Standard Rated Capacity Limiter and Anti-Two Block system

- Control function shutdown. Audible and visual warnings
- LCD screen provides a continuous display of working boom length, boom angle, working load radius, tip height, parts-of-line (operator set), machine track configuration, relative load moment, maximum permissible load and actual load.
- Anti-two block weight allows quick reeving of hook block

FRAME

The frame is an all-steel, welded structure, precision machined to accept attachment of the boom and swing components.

OPERATORS CAB

Fully-enclosed, air conditioned all-steel modular cab with lockable swinging door, acoustical lining, anti-slip floor and tinted safety glass.

- Rear view cameras are appropriately located as are three remote control work lights.
- Vent window in the rear of the cab.
- Grab bars and steps are located for easy access to the cab.
- Defroster, heater, circulating fan
- 2-speed windshield wiper, top glass wiper
- Six-way adjustable fabric seat with headrest, seat belt
- Dome light
- Dry-chemical fire extinguisher
- Two-way armrest mounted hydraulic joysticks control swing, boom extend, main winch, and boom hoist. Hydraulic foot pedals control the travel and swing service brake functions.
- Seat and armrest termination switches immediately disable all hydraulic functions as the operator rises from the seat or lifts the left hand armrest.

Dash instrumentation: tachometer, voltmeter, oil pressure gauge, temperature gauge, hour meter and fuel gauge. Indicators are provided for crane level, load moment, drum rotation, air filter restriction, hydraulic oil temperature and filter restriction, engine oil pressure and temperature.

ENGINE

- Make/ Model: Cummins QSB 6.7
- Type: 6 Cylinder, Water cooled, 4 Cycle
- Aspiration: Turbocharged and Charge Air Cooled
- Max. Output: 129 kw (173 hp) @ 2200 RPM
- Max Torque: 799 Nm @ 1400 RPM
- Piston Disp: 6.7 liter
- Emission Cert: U.S. EPA Tier 3, Euromot Stage IIIA

ELECTRICAL SYSTEM

12 VDC

FUEL SYSTEM

- Capacity: 378 liter
- Filtration: Inline fuel/water separator and engine mounted fuel filter

SIDE FRAMES

Two welded steel side frames are paired with a track group. The side frames extend and retract hydraulically and are controlled from the cab.

- Track Rollers: Two top and nine bottom sealed rollers on each track frame Idler: Oil filled, self lubricating with spring type tensioner
- Track Shoes: 760 mm, 3-bar semi grouser

HYDRAULIC SYSTEM

- Hydraulic Pumps: Two high pressure, variable axial piston pumps with load sense and power limiting control for crane functions. One hydraulic pump for cooling loop
- Directional Valves: Multiple pressure and flow compensated valves with integrated relief valves controlled by hydraulic pilot signals.
- Pump output: 437 l/min @ 2100 RPM engine speed. 330 bar maximum pressure
- Reservoir: 568 liter capacity, spin-on filler/ breather, sight gauge, cleanout, and sump drain.
- Filtration: 5 micron, full flow tank mounted return filters with electrical clogging indicator. 5 micron pilot oil in-line pressure filter
- Diagnostic Ports: Provided for system, load sense, and pilot pressure

OPTIONAL EQUIPMENT

- Boom Extension: Lattice type, swing away
 - Length: 6.1m
 - Head: Two, 483 mm diameter cast nylon sheaves on heavy-duty roller bearings
 - Max. Lifting Height: 29.5 m
- Boom Jib: Lattice type, swing away, stores along boom extension
 - Length: 6.1m
 - Offset Angles: 15° & 30°
 - Max. Lifting Height: 36.3 m
- Track Shoes: 610 mm 3-bar semi grouser
- Track Shoes: 457 mm 3-bar semi grouser
- Auger Ready Package: Includes hoses, fasteners and stowage bracket assembly mounted to the base section of the boom with a flow capability of 130 l/min
- Complete Auger Package: Adds a two speed auger motor/gear box and one 1.52 m kelly bar to the Auger Ready Package.
- Tool Circuit: Provides 23 l/min and 45 l/min at 176 bar through a 15.2m twin hose reel with quick disconnect fittings to operate open center tools.
- Free Fall Hoists: All winches are available in controlled free fall configurations.
- Cold Weather Packages: Cold weather options are available for operation to -40°C (Consult factory for application support)
- Pole Claw: Heavy-duty pole claw with hydraulic clamp and tilt.
- Access walkways
- Rotation resistant wire rope.
- 3 Color Light Bar for external load indication
- Travel Lever

MAIN WINCH

Planetary geared single-speed winch includes a bent axis, variable displacement hydraulic motor and a multi-disc internal brake.
Wire Rope: 183 m 14 mm 6 x 36 EIPS, IWRC, RRL. Line pulls are not based on wire rope strength. Drum rotation indicator is standard.

Rope Layer	Maximum Line Pull (kN)	Full Load Line Speed (m/min)	Pitch Diameter (mm)	Layer (m)	Total (m)
1	44.9	60.4	284.3	21.4	21.4
2	44.5	64.6	309.1	23.3	44.7
3	40.5	67.4	333.9	25.2	69.9
4	37.4	69.8	358.8	27.1	97.0
5	34.7	74.4	383.6	28.9	125.9
6	32.5	75.3	408.4	30.8	156.7
7	30.2	78.0	433.2	32.7	189.5

AUXILIARY HOIST

Planetary geared single-speed winch includes a bent axis, variable displacement hydraulic motor and a multi-disc internal brake.
Wire Rope: 91 m 14 mm 6 x 36 EIPS, IWRC, RRL Line pulls are not based on wire rope strength. Drum rotation indicator is standard.

Rope Layer	Maximum Line Pull (kN)	Full Load Line Speed (m/min)	Pitch Diameter (mm)	Layer (m)	Total (m)
1	53.4	55.5	261.9	20.1	20.1
2	48.0	60.4	286.8	22.0	42.1
3	43.6	62.5	311.6	23.9	66.1
4	40.0	65.2	336.4	25.8	91.9
5	36.9	69.5	361.2	27.7	119.6

MACHINE WEIGHTS

STANDARD CRANE WITH 3 SECTION 24.4 m BOOM, 1 PIECE COUNTERWEIGHT & 760 mm TRACK SHOES	27,210 kg
Crane Less Counterweight	21,990 kg
Counterweight	5,220 kg
Auxiliary Nose Sheave	68 kg
Auxiliary Winch with Standard Rope	275 kg
6t Headache Ball	74 kg
27t Hook Block	345 kg

OPTIONAL EQUIPMENT

6.10 m Lattice Extension	544 kg
6.10 m Jib (connects to head of Lattice Extension ONLY)	318 kg
Auger Ready Package	200 kg
Complete Auger Package	690 kg
1.52 m Auger Kelly Bar	54 kg
1.83 m Auger Kelly Bar	64 kg

GTC-300EX

27t Telescopic Boom Crawler Crane

SPECIFICATION SHEET NO. 541-09/11 ISO

DIMENSIONS

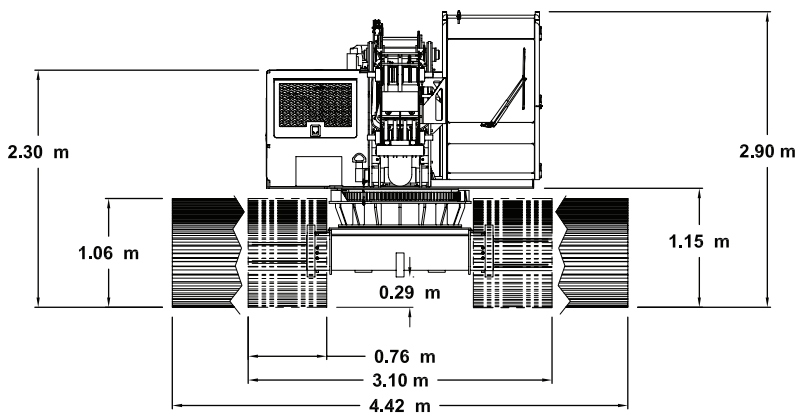
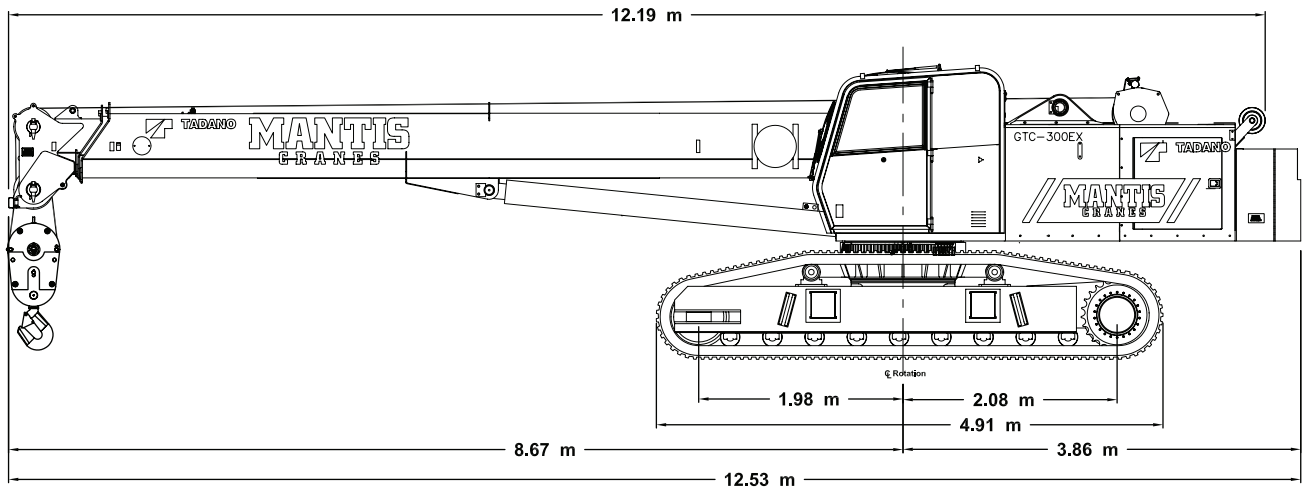

dzwigi24.pl

WIDTHS, WEIGHTS, AND GROUND PRESSURES*

Shoe Width	Overall Width		Area	Ground Pressure	Working Weight
	Retracted	Extended			
450 mm	2.59 m	4.11 m	3.72 m ²	0.74 kg/cm ²	27,445 kg
610 mm	2.95 m	4.27 m	4.95 m ²	0.56 kg/cm ²	27,971 kg
760 mm	3.10 m	4.42 m	6.19 m ²	0.46 kg/cm ²	28,495 kg

* Crane equipped with: 24.4m boom, extension, jib, 27t hook block, and 6.3t headache ball

24.4M MAIN BOOM, 6.1M EXTENSION & 6.1M JIB

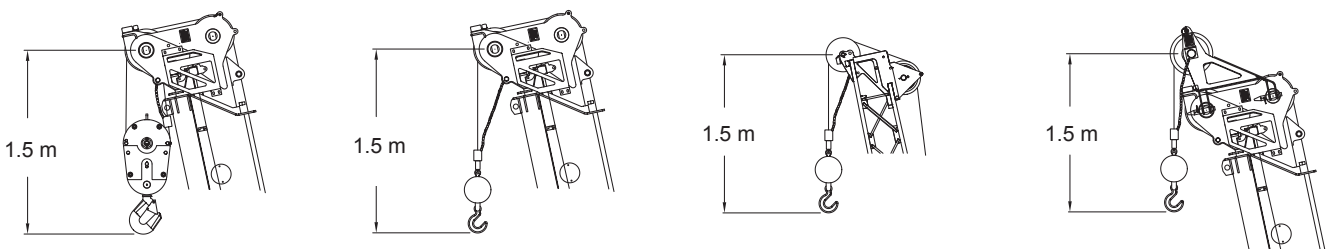
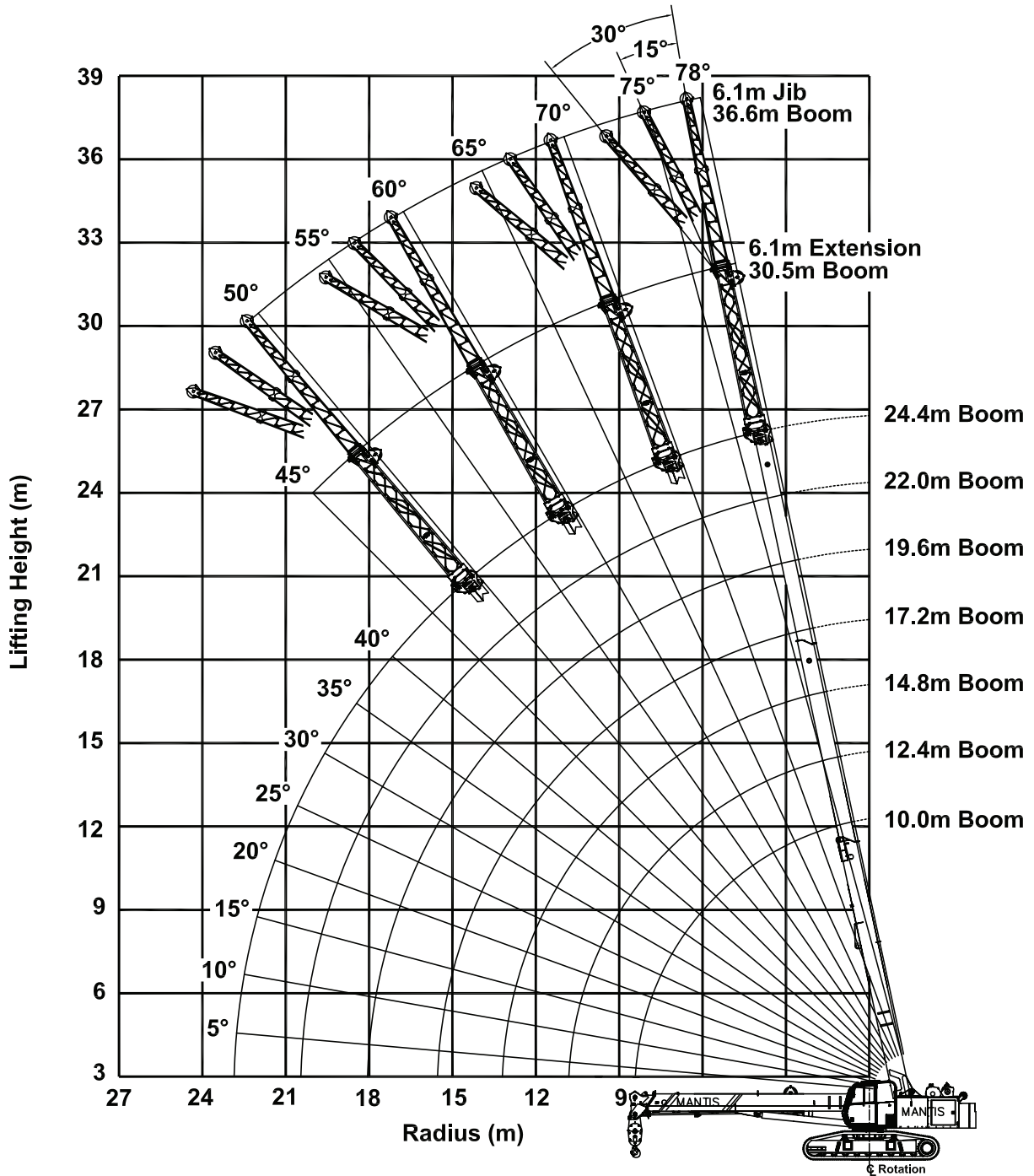

LOAD CHARTS



360 DEGREE RATING - LOADS IN kg x 1000

		MODE 1						
		MAIN BOOM - 5.2t COUNTERWEIGHT - TRACKS FULLY EXTENDED - NO TRAVEL - LEVEL UP TO 1°						
m	10.0	12.4	14.8	17.2	19.6	22.0	24.4	
2.5	27.2	21.8	21.6					
3.0	27.2	21.8	21.6	20.4				
3.5	25.9	21.8	21.6	18.9	15.5			
4.0	24.0	21.8	21.2	17.5	14.8	11.8		
4.5	20.2	19.3	18.5	16.2	13.7	11.8	10.3	
5.0	17.3	16.7	16.1	15.3	12.8	11.2	9.8	
6.0	13.0	13.0	12.7	11.6	11.1	9.8	8.6	
7.0	9.9	10.3	10.4	9.6	9.8	8.5	7.7	
8.0	7.9	8.2	8.5	8.1	8.3	7.5	6.9	
9.0		6.8	7.0	7.2	7.1	6.9	6.0	
10.0		5.6	5.9	6.0	6.0	6.0	5.6	
11.0			5.0	5.2	5.2	5.1	5.1	
12.0			4.3	4.5	4.5	4.5	4.5	
13.0			3.8	3.9	3.9	3.9	3.9	
14.0				3.4	3.4	3.4	3.4	
15.0				3.0	3.0	3.0	3.0	
16.0					2.7	2.7	2.7	
17.0					2.4	2.4	2.4	
18.0					2.1	2.1	2.1	
19.0						1.9	1.9	
20.0						1.6	1.7	
21.0							1.5	
22.0							1.3	
Parts of Line	7	6	6	5	4	4	3	
% Extension								
I	0%	17%	33%	50%	67%	83%	100%	
II	0%	17%	33%	50%	67%	83%	100%	

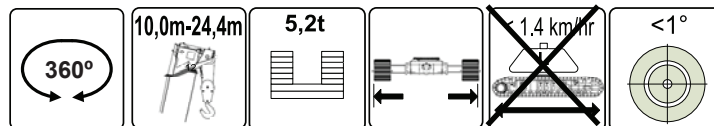

LOAD CHARTS



360 DEGREE RATING - LOADS IN kg x 1000

		MODE 1						
		MAIN BOOM - 5.2t COUNTERWEIGHT - TRACKS FULLY EXTENDED - TRAVEL TO 1.4 km/hr - LEVEL UP TO 1°						
m		10.0	12.4	14.8	17.2	19.6	22.0	24.4
2.5		27.2	21.8	21.6				
3.0		27.2	21.8	21.6	20.4			
3.5		25.9	21.8	21.6	18.9	15.5		
4.0		23.0	21.7	20.5	17.5	14.8	11.8	
4.5		19.5	18.5	17.7	16.2	13.7	11.8	10.3
5.0		16.8	16.1	15.5	14.9	12.8	11.2	9.8
6.0		12.2	12.5	12.3	11.9	11.1	9.8	8.6
7.0		9.3	9.6	9.9	9.8	9.4	8.5	7.7
8.0		7.4	7.7	8.0	8.1	8.0	7.5	6.9
9.0			6.3	6.6	6.7	6.7	6.7	6.0
10.0			5.3	5.6	5.7	5.7	5.7	5.6
11.0				4.7	4.9	4.9	4.8	4.9
12.0				4.1	4.2	4.2	4.2	4.2
13.0				3.5	3.7	3.7	3.7	3.7
14.0					3.2	3.2	3.2	3.2
15.0					2.8	2.8	2.8	2.8
16.0						2.5	2.5	2.5
17.0						2.2	2.2	2.2
18.0						2.0	2.0	2.0
19.0							1.7	1.8
20.0							1.5	1.6
21.0								1.4
22.0								1.2
Parts of Line		7	6	6	5	4	4	3
% Extension								
I		0%	17%	33%	50%	67%	83%	100%
II		0%	17%	33%	50%	67%	83%	100%

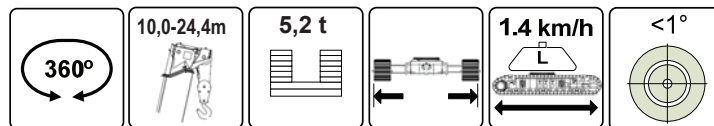

LOAD CHARTS

dzwigi24.pl

360 DEGREE RATING - LOADS IN kg x 1000

		MODE 1						
		MAIN BOOM - 5.2t COUNTERWEIGHT - TRACKS FULLY EXTENDED - NO TRAVEL - OUT OF LEVEL 1° TO 4°						
m	10.0	12.4	14.8	17.2	19.6	22.0	24.4	
2.5	24.5	18.9	18.6					
3.0	22.6	18.9	18.0	16.3				
3.5	18.9	17.0	15.5	14.2	12.1			
4.0	16.2	14.8	13.6	12.6	11.5	9.2		
4.5	14.1	13.0	12.1	11.2	10.4	9.2	8.1	
5.0	12.4	11.5	10.8	10.1	9.4	8.7	7.7	
6.0	10.0	9.4	8.9	8.4	7.9	7.4	6.7	
7.0	8.3	7.8	7.5	7.1	6.7	6.3	6.0	
8.0	7.0	6.6	6.4	6.1	5.8	5.4	5.2	
9.0		5.7	5.5	5.3	5.0	4.7	4.5	
10.0		5.0	4.9	4.7	4.4	4.2	4.0	
11.0			4.3	4.1	3.9	3.7	3.5	
12.0			3.9	3.7	3.5	3.3	3.2	
13.0			3.3	3.3	3.1	2.9	2.8	
14.0				3.0	2.8	2.6	2.5	
15.0				2.7	2.5	2.4	2.3	
16.0					2.3	2.1	2.0	
17.0					2.1	1.9	1.8	
18.0					1.8	1.8	1.7	
19.0						1.6	1.5	
20.0						1.4	1.4	
21.0							1.2	
22.0							1.1	
Parts of Line	7	6	6	5	4	4	3	
% Extension								
I	0%	17%	33%	50%	67%	83%	100%	
II	0%	17%	33%	50%	67%	83%	100%	

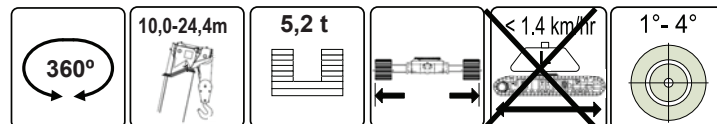

LOAD CHARTS

360 DEGREE RATING - LOADS IN kg x 1000

	MODE 1 MAIN BOOM - 5.2t COUNTERWEIGHT - TRACKS FULLY EXTENDED - TRAVEL TO 1.4 km/hr - OUT OF LEVEL 1° TO 4°						
	m	10.0	12.4	14.8	17.2	19.6	22.0
2.5	24.5	18.9	18.6				
3.0	21.7	18.9	17.1	15.4			
3.5	18.3	16.4	14.8	13.5	12.1		
4.0	15.8	14.3	13.1	12.1	11.1	9.2	
4.5	13.7	12.5	11.6	10.8	10.0	9.2	8.1
5.0	12.4	11.4	10.6	9.8	9.1	8.5	7.7
6.0	9.8	9.1	8.6	8.1	7.6	7.1	6.7
7.0	8.3	7.7	7.3	6.9	6.5	6.1	5.8
8.0	6.7	6.6	6.3	6.0	5.6	5.3	5.0
9.0		5.6	5.4	5.2	4.9	4.6	4.4
10.0		4.7	4.8	4.6	4.3	4.1	3.9
11.0			4.2	4.1	3.8	3.6	3.5
12.0			3.6	3.6	3.4	3.2	3.1
13.0			3.1	3.3	3.1	2.9	2.8
14.0				2.9	2.8	2.6	2.5
15.0				2.5	2.5	2.3	2.2
16.0					2.2	2.1	2.0
17.0					1.9	1.9	1.8
18.0					1.7	1.7	1.6
19.0						1.5	1.5
20.0						1.3	1.3
21.0							1.2
22.0							1.0
Parts of Line	7	6	6	5	4	4	3
% Extension							
I	0%	17%	33%	50%	67%	83%	100%
II	0%	17%	33%	50%	67%	83%	100%

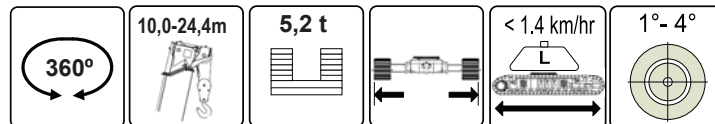

dzwigi24.pl

LOAD CHARTS

360 DEGREE RATING - LOADS IN kg x 1000

	MODE 2 MAIN BOOM - 0t COUNTERWEIGHT - TRACKS FULLY EXTENDED - NO TRAVEL - LEVEL UP TO 1°						
	m	10.0	12.4	14.8	17.2	19.6	22.0
2.5	27.2	21.8	21.6				
3.0	22.8	21.1	19.6	18.2			
3.5	17.7	16.7	15.7	14.8	13.9		
4.0	14.3	13.6	13.0	12.4	11.7	11.1	
4.5	11.9	11.4	11.1	10.6	10.1	9.6	9.2
5.0	10.1	9.8	9.5	9.2	8.8	8.4	8.0
6.0	7.4	7.4	7.3	7.2	6.9	6.6	6.4
7.0	5.5	5.8	5.8	5.8	5.5	5.3	5.2
8.0	4.1	4.5	4.8	4.7	4.5	4.4	4.3
9.0		3.5	3.8	3.9	3.8	3.6	3.6
10.0		2.8	3.1	3.2	3.2	3.1	3.0
11.0			2.5	2.7	2.7	2.6	2.5
12.0			2.1	2.2	2.2	2.2	2.2
13.0			1.7	1.9	1.9	1.8	1.8
14.0				1.6	1.5	1.5	1.5
15.0				1.3	1.3	1.3	1.3
16.0					1.1	1.0	1.1
17.0					0.9	0.9	0.9
18.0					0.7	0.7	0.7
19.0						0.5	0.6
20.0						0.4	0.4
21.0							*
22.0							*
Parts of Line	7	6	6	5	4	4	3
% Extension							
I	0%	17%	33%	50%	67%	83%	100%
II	0%	17%	33%	50%	67%	83%	100%

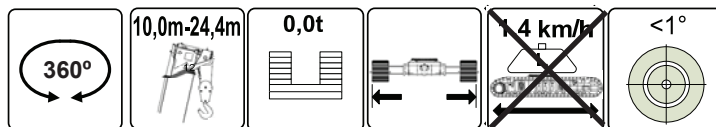

LOAD CHARTS

360 DEGREE RATING - LOADS IN kg x 1000

	MODE 2 MAIN BOOM - 0t COUNTERWEIGHT - TRACKS FULLY EXTENDED - TRAVEL TO 1.4 km/hr - LEVEL UP TO 1°							
	m	10.0	12.4	14.8	17.2	19.6	22.0	24.4
2.5	27.2	21.8	21.6					
3.0	21.4	19.7	18.2	16.9				
3.5	16.8	15.8	14.8	13.9	13.0			
4.0	13.7	13.0	12.4	11.7	11.0	10.4		
4.5	11.4	11.0	10.5	10.1	9.5	9.0	8.6	
5.0	9.7	9.4	9.1	8.8	8.3	7.9	7.6	
6.0	7.0	7.2	7.1	6.9	6.6	6.3	6.0	
7.0	5.1	5.5	5.7	5.5	5.3	5.1	4.9	
8.0	3.9	4.2	4.5	4.6	4.4	4.2	4.1	
9.0		3.3	3.6	3.7	3.7	3.5	3.4	
10.0		2.7	2.9	3.0	3.0	3.0	2.9	
11.0			2.4	2.5	2.5	2.5	2.4	
12.0			2.0	2.1	2.1	2.1	2.1	
13.0			1.6	1.8	1.7	1.7	1.7	
14.0				1.5	1.5	1.4	1.5	
15.0				1.2	1.2	1.2	1.2	
16.0					1.0	1.0	1.0	
17.0					0.8	0.8	0.8	
18.0					0.6	0.6	0.7	
19.0						0.5	0.5	
20.0						0.4	0.4	
21.0							*	
22.0							*	
Parts of Line	7	6	6	5	4	4	3	
% Extension								
I	0%	17%	33%	50%	67%	83%	100%	
II	0%	17%	33%	50%	67%	83%	100%	

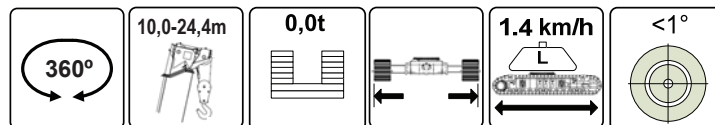

LOAD CHARTS

360 DEGREE RATING - LOADS IN kg x 1000

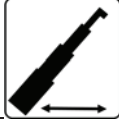
	MODE 2						
	MAIN BOOM - 0t COUNTERWEIGHT - TRACKS FULLY EXTENDED - NO TRAVEL - OUT OF LEVEL 1° TO 4°						
m	10.0	12.4	14.8	17.2	19.6	22.0	24.4
2.5	17.8	15.4	13.5				
3.0	14.2	12.6	11.3	10.2			
3.5	11.8	10.6	9.7	8.8	8.0		
4.0	9.9	9.1	8.4	7.7	7.1	6.5	
4.5	8.5	7.9	7.4	6.8	6.3	5.8	5.4
5.0	7.4	6.9	6.5	6.1	5.6	5.2	4.9
6.0	5.7	5.5	5.2	4.9	4.6	4.3	4.0
7.0	4.6	4.4	4.3	4.1	3.8	3.5	3.3
8.0	3.8	3.6	3.5	3.4	3.2	3.0	2.8
9.0		3.0	3.0	2.9	2.7	2.5	2.4
10.0		2.5	2.5	2.4	2.3	2.1	2.0
11.0			2.1	2.1	1.9	1.8	1.7
12.0			1.8	1.8	1.6	1.5	1.4
13.0			1.6	1.5	1.4	1.3	1.2
14.0				1.3	1.2	1.1	1.0
15.0				1.2	1.0	0.9	0.8
16.0					0.9	0.7	0.7
17.0					0.7	0.6	0.5
18.0					0.6	0.5	0.4
19.0						0.4	*
20.0						*	*
21.0							*
22.0							*
Parts of Line	6	6	5	4	3	2	2
% Extension							
I	0%	17%	33%	50%	67%	83%	100%
II	0%	17%	33%	50%	67%	83%	100%

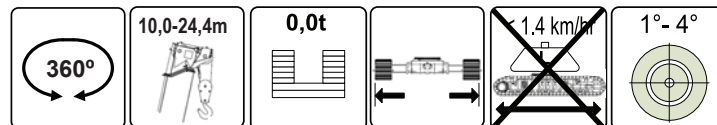

LOAD CHARTS

360 DEGREE RATING - LOADS IN kg x 1000

	MODE 3 MAIN BOOM - 5.2t COUNTERWEIGHT - TRACKS RETRACTED - NO TRAVEL - LEVEL UP TO 1°						
	10.0	12.4	14.8	17.2	19.6	22.0	24.4
m	10.0	12.4	14.8	17.2	19.6	22.0	24.4
3.5	*	*	*	*	*		
4.0	12.5	*	*	*	*	*	
4.5	10.7	10.4	*	*	*	*	*
5.0	9.3	9.1	8.9	8.7	8.3	8.0	7.7
6.0	7.0	7.2	7.1	7.0	6.7	6.5	6.3
7.0	5.4	5.7	5.8	5.7	5.5	5.4	5.2
8.0	4.2	4.5	4.8	4.8	4.7	4.5	4.4
9.0		3.7	3.9	4.1	3.9	3.8	3.7
10.0		3.0	3.3	3.4	3.4	3.3	3.2
11.0			2.7	2.9	2.9	2.8	2.8
12.0			2.3	2.4	2.4	2.4	2.4
13.0			1.9	2.1	2.1	2.0	2.1
14.0				1.8	1.8	1.7	1.8
15.0				1.5	1.5	1.5	1.5
16.0					1.3	1.3	1.3
17.0					1.1	1.1	1.1
18.0					0.9	0.9	0.9
19.0						0.7	0.7
20.0						0.6	0.6
21.0							0.5
22.0							0.4
Parts of Line	6	6	5	4	3	2	2
% Extension							
I	0%	17%	33%	50%	67%	83%	100%
II	0%	17%	33%	50%	67%	83%	100%

dzwigi24.pl

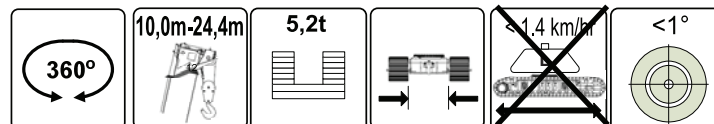

LOAD CHARTS

360 DEGREE RATING - LOADS IN kg x 1000

	MODE 3						
	MAIN BOOM - 5.2t COUNTERWEIGHT - TRACKS						
	RETRACTED - TRAVEL TO 1.4 km/hr - LEVEL UP TO 1°						
m	10.0	12.4	14.8	17.2	19.6	22.0	24.4
3.5	*	*	*	*	*		
4.0	12.0	*	*	*	*	*	
4.5	10.4	10.0	*	*	*	*	*
5.0	8.9	8.8	8.6	8.3	7.9	7.6	7.3
6.0	6.6	6.9	6.9	6.7	6.4	6.2	6.0
7.0	5.1	5.3	5.6	5.5	5.3	5.1	5.0
8.0	4.0	4.3	4.5	4.6	4.5	4.3	4.2
9.0		3.5	3.7	3.8	3.8	3.7	3.6
10.0		2.8	3.1	3.2	3.2	3.2	3.1
11.0			2.6	2.7	2.7	2.7	2.6
12.0			2.2	2.3	2.3	2.3	2.3
13.0			1.8	1.9	1.9	1.9	1.9
14.0				1.7	1.6	1.6	1.6
15.0				1.4	1.4	1.4	1.4
16.0					1.2	1.2	1.2
17.0					1.0	1.0	1.0
18.0					0.8	0.8	0.8
19.0						0.7	0.7
20.0						0.5	0.6
21.0							0.5
22.0							*
Parts of Line	6	6	5	4	3	2	2
% Extension							
I	0%	17%	33%	50%	67%	83%	100%
II	0%	17%	33%	50%	67%	83%	100%

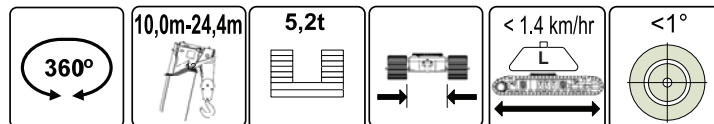

LOAD CHARTS

360 DEGREE RATING - LOADS IN kg x 1000

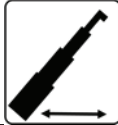
	MODE 17 NOSE SHEAVE - 5.2t COUNTERWEIGHT - TRACKS FULLY EXTENDED - TRAVEL TO 1.4 km/hr - LEVEL UP TO 1°						
	m	10.0	12.4	14.8	17.2	19.6	22.0
2.5	2.7	2.7	2.7				
3.0	2.7	2.7	2.7	2.7			
3.5	2.7	2.7	2.7	2.7	2.7		
4.0	2.7	2.7	2.7	2.7	2.7	2.7	
4.5	2.7	2.7	2.7	2.7	2.7	2.7	2.7
5.0	2.7	2.7	2.7	2.7	2.7	2.7	2.7
6.0	2.7	2.7	2.7	2.7	2.7	2.7	2.7
7.0	2.7	2.7	2.7	2.7	2.7	2.7	2.7
8.0	2.7	2.7	2.7	2.7	2.7	2.7	2.7
9.0		2.7	2.7	2.7	2.7	2.7	2.7
10.0		2.7	2.7	2.7	2.7	2.7	2.7
11.0			2.7	2.7	2.7	2.7	2.7
12.0			2.7	2.7	2.7	2.7	2.7
13.0			2.7	2.7	2.7	2.7	2.7
14.0				2.7	2.7	2.7	2.7
15.0				2.7	2.7	2.7	2.7
16.0					2.4	2.4	2.4
17.0					2.1	2.1	2.1
18.0					1.9	1.9	1.9
19.0						1.7	1.7
20.0						1.5	1.5
21.0							1.3
22.0							1.2
Parts of Line	1	1	1	1	1	1	1
% Extension							
I	0%	17%	33%	50%	67%	83%	100%
II	0%	17%	33%	50%	67%	83%	100%

dzwigi24.pl

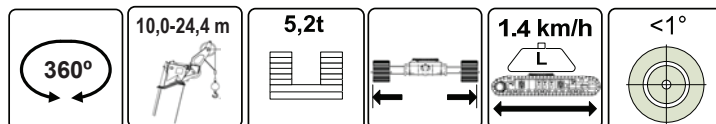

LOAD CHARTS

360 DEGREE RATING - LOADS IN kg x 1000

	MODE 19 NOSE SHEAVE - 5.2t COUNTERWEIGHT - TRACKS RETRACTED - TRAVEL TO 1.4 km/hr - LEVEL UP TO 1°						
	m	10.0	12.4	14.8	17.2	19.6	22.0
3.5	*	*	*	*	*		
4.0	2.7	*	*	*	*	*	
4.5	2.7	2.7	*	*	*	*	*
5.0	2.7	2.7	2.7	2.7	2.7	2.7	2.7
6.0	2.7	2.7	2.7	2.7	2.7	2.7	2.7
7.0	2.7	2.7	2.7	2.7	2.7	2.7	2.7
8.0	2.7	2.7	2.7	2.7	2.7	2.7	2.7
9.0		2.7	2.7	2.7	2.7	2.7	2.7
10.0		2.7	2.7	2.7	2.7	2.7	2.7
11.0			2.5	2.6	2.6	2.6	2.6
12.0			2.1	2.2	2.2	2.2	2.2
13.0			1.7	1.9	1.8	1.8	1.8
14.0				1.6	1.6	1.5	1.6
15.0				1.3	1.3	1.3	1.3
16.0					1.1	1.1	1.1
17.0					0.9	0.9	0.9
18.0					0.7	0.7	0.8
19.0						0.6	0.6
20.0						0.5	0.5
21.0							0.4
22.0							*
Parts of Line	1	1	1	1	1	1	1
% Extension							
I	0%	17%	33%	50%	67%	83%	100%
II	0%	17%	33%	50%	67%	83%	100%

dzwigi24.pl

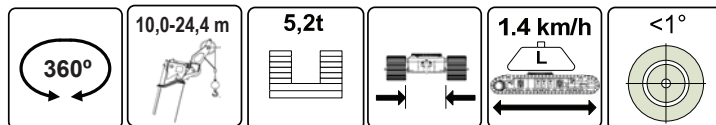

LOAD CHARTS

dzwigi24.pl

360 DEGREE RATING - LOADS IN kg x 1000

6.1m EXTENSION & 6.1m JIB						
with TRACKS FULLY EXTENDED - TRAVEL TO 1.4 km/hr - LEVEL TO 1°						
5.2t COUNTERWEIGHT						
6.1m EXTENSION			6.1m JIB			Boom Angle
Boom Angle	Total Boom Length		All Boom Lengths Jib Offset Angles			
	16.1m to 28.0m	> 28.0m	0°	15°	30°	
78°	5.6	5.6	3.0	1.8	1.0	78°
75°	4.8	4.8	2.9	1.8	1.0	75°
72°	4.2	4.2	2.5	1.6	0.9	72°
70°	3.9	3.7	2.3	1.5	0.9	70°
68°	3.6	3.4	2.1	1.4	0.8	68°
65°	3.3	2.8	1.9	1.3	0.8	65°
62°	3.0	2.3	1.8	1.2	0.8	62°
60°	2.8	2.0	1.6	1.1	0.8	60°
58°	2.7	1.8	1.5	0.9	0.6	58°
55°	2.5	1.5	1.2	0.6	0.5	55°
52°	2.4	1.4	0.9	0.3	0.2	52°
50°	2.3	1.2	0.7	0.1	0.1	50°
48°	2.0	1.1				48°
45°	1.9	0.9				45°

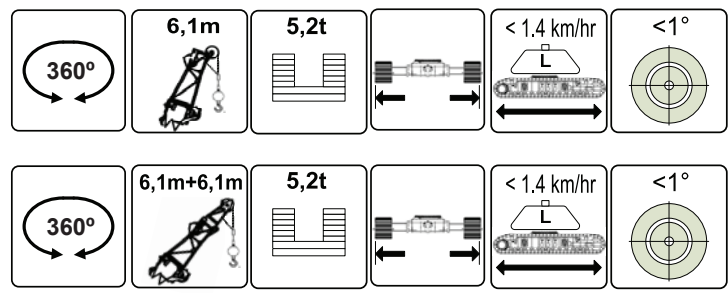

dzwigi24.pl

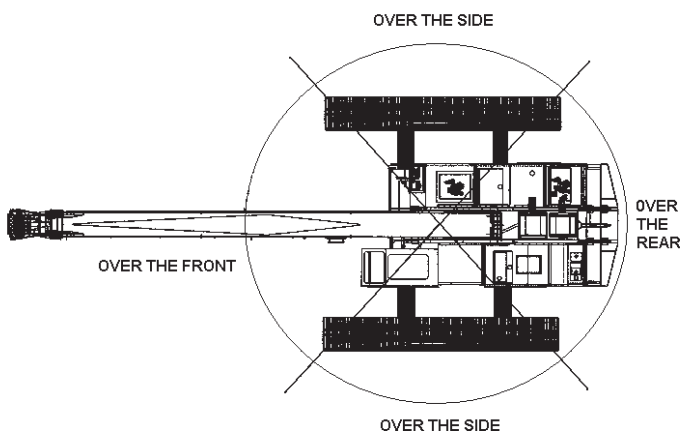

TADANO MANTIS GTC-300EX				
WIRE ROPE LINE PULL CAPACITIES				
PARTS OF LINE	MAIN WINCH (kN)	AUX WINCH (kN)	PARTS OF LINE	MAIN WINCH (kN)
1	42.7	42.7	5	204.2
2	83.5	83.5	6	243.3
3	124.4	N/A	7	281.8
4	164.6	N/A	N/A	N/A

14mm diameter wire rope, 6 x 36 IWRC EIPS

PLEASE READ, UNDERSTAND, AND FOLLOW THE MANUALS FURNISHED WITH THE CRANE (OPERATORS AND SAFETY) AS WELL AS THE CAPACITY LIMITATIONS AND GENERAL CONDITIONS LISTED BELOW PRIOR TO OPERATION OF THE CRANE. FAILURE TO DO SO MAY RESULT IN AN ACCIDENT.

This **MANTIS CRANE** as manufactured by **Tadano Mantis Corporation** meets the requirements of **ISO4301/2** or **4308/2**. Structure and stability have been tested in accordance with this standard. Lifting capacities as determined by boom length, angle or radius, apply only to machines as originally equipped by manufacturer and in a properly maintained condition. Capacities given are maximum covered by the manufacturers warranty and are based on a freely suspended load with **NO** allowance for factors as out-of-level operation (beyond the limits specified on the charts), supporting surface conditions, hazardous surroundings, experience of personnel, etc. The operator shall establish practical working loads based on prevailing operating conditions, such as, but not limited to the above. If your application varies from the conditions as set forth in ISO 4301/2 or ISO4308/2 consult your Tadano Mantis Service department for recommendations on adjustments to the rated capacity of the crane.

When making lifts where capacities may be within a zone limited by structural strength, the operator shall determine that the weight of the load is known within plus or minus (+/-) ten percent (10%) before making lift. **DO NOT** lift load or extend boom without counterweight in place. Deductions from rated capacities must be made for the weight of the hook block, hook/ball, slings, spreader bar, or other suspended equipment.

Side pull on boom is extremely dangerous and must be avoided.

DO NOT exceed manufacturers maximum specified reeving.

DO NOT use this chart if wind speed exceeds 36 km/h. Consult the manufacturer for specialized load ratings.

Load radius is defined as the horizontal distance from the axis of rotation (with no load) to the center of the lifting device after load is applied. Boom angle is the included angle between the longitudinal axis of the boom base section and the Horizontal axis, after lifting load. The boom angle before lifting should be slightly greater than desired to account for boom deflection.

Boom angle/boom length relationships given are an approximation of the resulted load radius, which should be an accurate measurement. Boom height dimensions are measured from ground to center of lower boom head sheave.

It is permissible to attempt to telescope boom with a load within the limits of rated capacities. However, boom angle system hydraulic pressure, and/or boom lubrication may affect operation.

It is permissible to travel with loads within the rated capacity of the crane. Travel speeds should be greatly reduced to reflect terrain limitations and minimize dynamic loads applied to the crane structure.

Load moment indicating and anti-two block systems are operator aids and must never be used in lieu of job site lift planning calculations by the operator which must take into account ground conditions, weather and all other environmental factors prevailing at the time of the lift. Prices and specifications are subject to change at any time without prior notice and are for factory installation at the time of original manufacture. Illustrations and photographs may show optional equipment. Supercedes all previous issues. Please see www.mantiscranes.com for most current information.

TADANO MANTIS CORPORATION

1705 Columbia Avenue • Franklin, TN 37064 USA • Toll-Free: 1-800-272-3325 • Fax: 615-790-6803 • mantiscranes.com

dzwigi24.pl

TADANO Ltd., International Division

4-12, Kamezawa 2-chome,
Sumida-Ku, Tokyo 130-0014, Japan

Tel: +81 3 3621 7750

Fax: +81 3 3621 7785

E-mail: tdnihq@tadano.co.jp

www.tadano.co.jp/indexe.html

SPECIFICATION SHEET NO. 541-09/11 ISO