

dzwigi24.pl

GTC-400EX

40t Telescopic Boom Crawler Crane



 TADANO

MANTIS
CRANES

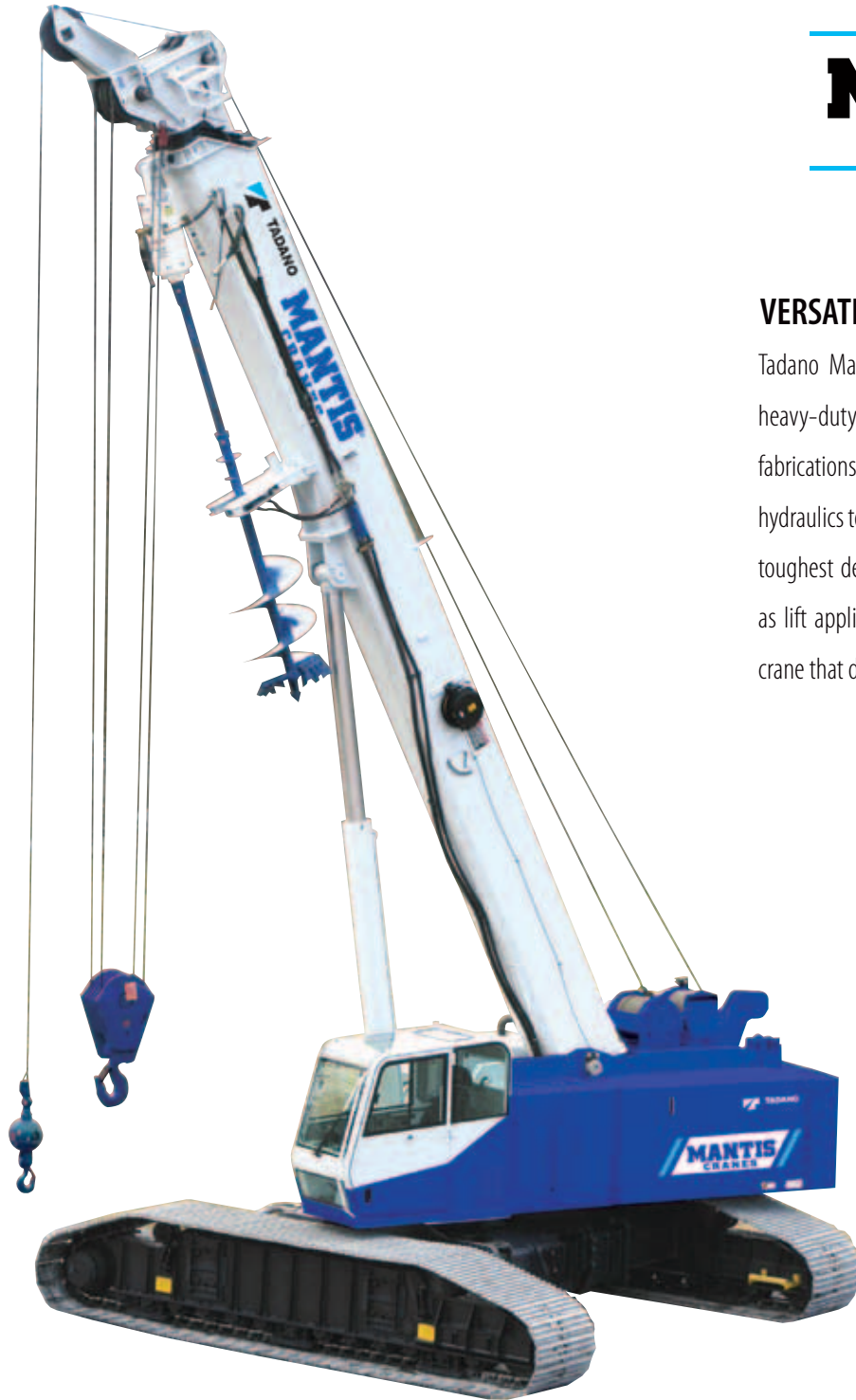

VERSATILE. POWERFUL. DEPENDABLE.

Tadano Mantis cranes are engineered as VERSATILE, heavy-duty machines. We match massive steel fabrications with diesel engines and state of the art hydraulics to provide a POWERFUL crane that meets the toughest demands in full load pick-and-carry as well as lift applications. MANTIS... the one DEPENDABLE crane that does it all on your jobsite

OPTIONAL EQUIPMENT

ACCESS WALKWAYS



AUGER KIT AND POLE CLAW



LIGHT BAR AND TOOL CIRCUIT



FEATURES

NO OTHER CRANE COMBINES SO MANY VALUABLE FEATURES:

- Pick-and-carry the full crane load chart through 360°.
- Lift and walk...even with tracks retracted.
- Climb steeper grades, thanks to minimized counterweight and low center of gravity.
- Pull through deep mud without bogging down.
- Telescope or lift the boom with a full load on the hook.
- Save time and money on the job due to low clearance height, retract on-the-fly tracks and telescopic boom.
- Independent hydrostatic track drives allow pivot turns and counter rotation
- Hydraulic tool circuit option powers wide choice of Mantis-approved tools.



Large access doors, spacious machinery compartments simplify preventative maintenance and service of the crane.



Conveniently positioned cameras display the winch as well as the blind area directly behind the crane. Full color video display in operator cab is standard equipment.



Spacious cab, adjustable seat, and conveniently located controls are common in all Tadano Mantis Cranes.



State-of-the-art, user friendly rated capacity limiter provides continuous feedback of crane lift and position data.

SPECIFICATIONS

CAPACITY

40t at 3.0m

BOOM

4-section full power synchronized telescoping boom. Synchronized telescoping system consists of two double acting hydraulic cylinders with load holding valves and extension and retraction cables.

- Retracted Length: 10,4 m
- Extended Length: 32,0 m
- Extension Time: 91 s
- Elevating Time: 44 s
- Elevating Angles: -1° to 78°
- Boom Head: Six, 483 mm diameter cast nylon sheaves on heavy-duty roller bearings (4 load sheaves and 2 lead in sheaves)
- Auxiliary Boom Head: Quick reeve, single 483 mm diameter high-strength, cast nylon sheave mounted on a heavy-duty roller bearing.
- Hook Block: 40t hook block - Four 483 mm diameter sheaves mounted on heavy duty roller bearings with swivel hook and safety latch.
- Headache Ball: 11t ball includes a swivel hook with a safety latch.

WINCHES

Planetary geared two-speed winch includes a bent axis hydraulic motor, multi-disc internal brake and counterbalance valve. Drum rotation indicator is included

- Main Winch
 - Rope Diameter and Length: 16mm x 183m
 - Single line pull: 69,5 kN (first layer)
 - Single line speed: 75,0 m/min (at the 4th layer)
- Auxiliary Winch
 - Rope Diameter and Length: 16mm x 107m
 - Single line pull: 69,5 kN (first layer)
 - Single line speed: 75,0 m/min (at the 4th layer)

TRAVEL

Each side frame contains a pilot controlled, two-speed track drive with hydraulic axial piston motor and parking brake. Travel system provides skid steering and counter rotation.

- Travel Speed (Low/High) 1,3 km/h / 2,1 km/h
- Gradeability (unladen): 68%

LOAD MOMENT INDICATOR & ANTI -TWO BLOCK

Standard Rated Capacity Limiter and Anti-Two Block system

- Control function shutdown. Audible and visual warnings
- LCD screen provides a continuous display of working boom length, boom angle, working load radius, tip height, parts-of-line (operator set), machine track configuration, relative load moment, maximum permissible load and actual load.

OPERATOR'S CAB

Fully-enclosed, air conditioned all-steel modular cab with lockable swinging door, acoustical lining, anti-slip floor and tinted safety glass.

- Rear view cameras are appropriately located as are three remote control work lights.
- 2-speed windshield wiper, top glass wiper
- Six-way adjustable fabric seat with headrest, seat belt
- Four, two-way hydraulic armrest mounted joysticks control swing, main winch, auxiliary winch and boom hoist. Foot pedals control the travel, boom extend, and swing service brake functions.
- Seat and armrest termination switches immediately disable all hydraulic functions as the operator rises from the seat or lifts the left hand armrest.

Dash instrumentation: tachometer, voltmeter, oil pressure gauge, temperature gauge, hour meter and fuel gauge. Indicators are provided for crane level, load moment, drum rotation, air filter restriction, hydraulic oil temperature and filter restriction, engine oil pressure and temperature.

ENGINE

- Make/ Model: Cummins QSB 6.7
- Rating: 194 kW (260 hp) @ 2200 RPM

ELECTRICAL SYSTEM

12 VDC

COUNTERWEIGHT

Total 6,804 kg rear counterweight

SWING

Gear motor driving a planetary gear reducer with a shaft mounted pinion, external gear shear ball slew bearing bolted to the superstructure and the carbody allows the superstructure to rotate 360°

- Swing Speed: 0 - 2.2 rpm
- Swing Parking Brake: Spring applied failsafe brake with hydraulic release that is controlled from the operators cab
- Swing Service Brake: Hydraulically applied, controlled through foot actuated pedal
- House Lock System: 2-position, manually pinned

HYDRAULIC SYSTEM

- Hydraulic Pumps: Two high pressure, variable axial piston pumps with load sense and power limiting control for crane functions. One variable axial piston pump for cooling loop
- Directional Valves: Multiple pressure and flow compensated valves with integrated relief valves controlled by hydraulic pilot signals.
- Pump output: 583 liter/min @ 2100 RPM engine speed. 330 bar maximum pressure
- Filtration: 5 micron

SIDE FRAMES

Two welded steel side frames are paired with a track group. The side frames extend and retract hydraulically and are controlled from the cab.

- Track Rollers: Two top and thirteen bottom sealed rollers on each track frame
- Idler: Oil filled, self lubricating with spring type tensioner
- Track Shoes: 900mm 3-bar semi grouser

OPTIONAL EQUIPMENT

- Boom Extension: Lattice type, swing away
 - Length: 9,1m
 - Head: Two, 483 mm diameter cast nylon sheaves on heavy-duty roller bearings
 - Max. Lifting Height: 41,2 m
- Boom Jib: Lattice type, swing away, stores along boom extension
 - Length: 6,1 m
 - Max. Lifting Height: 47,0 m
 - Offset Angles: 15° & 30°
- Auger Ready Package: Includes hoses, fasteners and stowage bracket assembly mounted to the base section of the boom with a flow capability of 130 liter/min
- Complete Auger Package: Adds a two speed auger motor/gear box and one 1,52m kelly bar to the Auger Ready Package.
- Tool Circuit: Provides 23 liter/min and 45 liter/min at 176 bar through a 15,24m twin hose reel with quick disconnect fittings to operate open center tools.
- Free Fall Hoists: All winches are available in controlled free fall configurations.
- 3-Color Light bar for external load indication
- Pole Claw: Heavy duty pole claw with hydraulic open/close and tilt.
- Access Walkways
- Travel Lever

DIMENSIONS

GTC-400EX

40t Telescopic Boom Crawler Crane

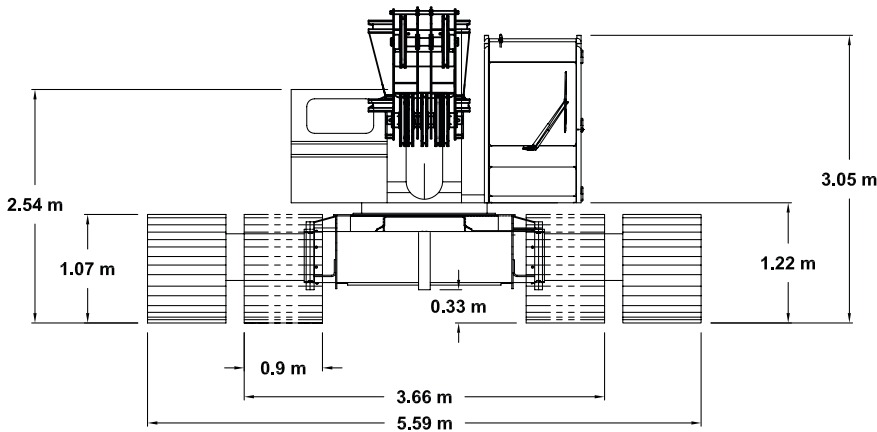
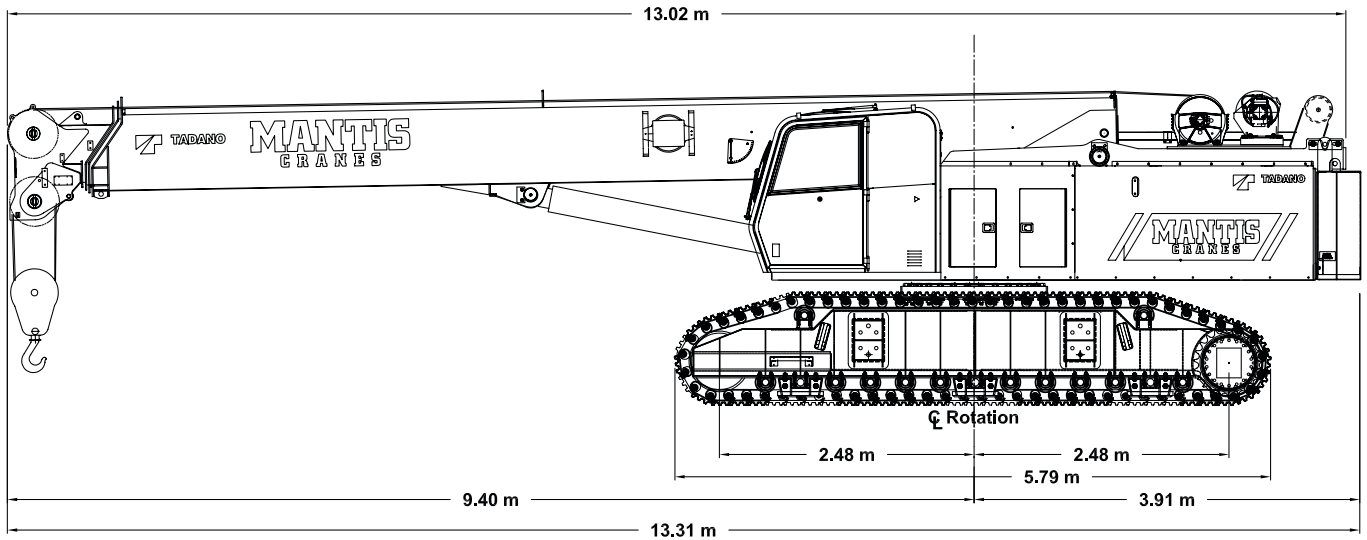

32M MAIN BOOM, 9,1M EXTENSION & 6,1M JIB

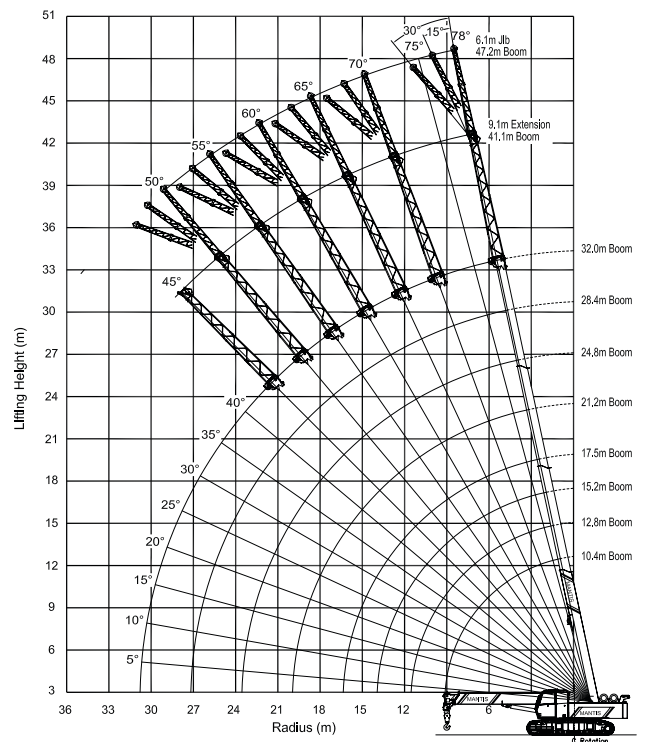

WIDTHS, WEIGHTS, AND GROUND PRESSURES*

Shoe Width	Overall Width		Area	Ground Pressure	Working Weight
	Retracted	Extended			
610 mm	3.35 m	5.22 m	6.04 m ²	0.68 kg/cm ²	40,800 kg
760 mm	3.51 m	5.39 m	7.55 m ²	0.51 kg/cm ²	41,700 kg
900 mm	3.66 m	5.59 m	9.06 m ²	0.47 kg/cm ²	42,590 kg

* Crane equipped with: 32m boom, extension, jib 40t hook block, 11t headache ball

TADANO MANTIS CORPORATION

1705 Columbia Avenue • Franklin, TN 37064 USA • Toll-Free: 1-800-272-3325 • Fax: 615-790-6803 • mantiscranes.com

GTC-300EX 27t Telescopic Boom Crawler Crane

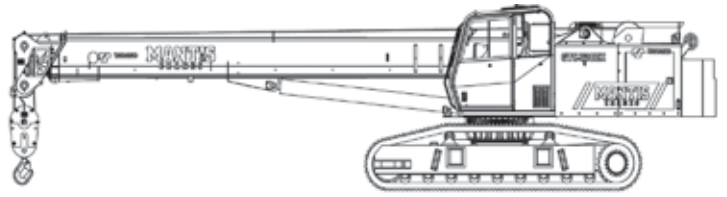

GTC-400EX 40t Telescopic Boom Crawler Crane

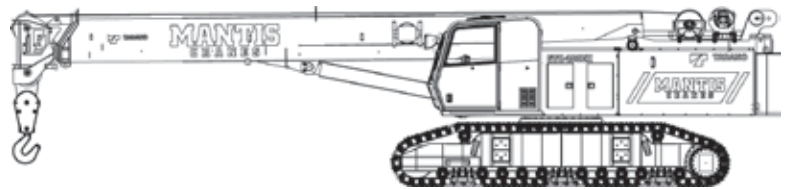

GTC-700EX 70t Telescopic Boom Crawler Crane

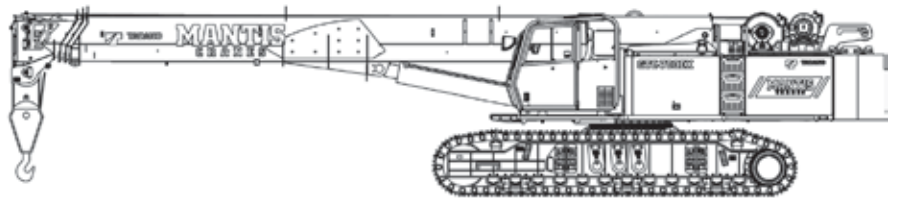

GTC-1000EX 100t Telescopic Boom Crawler Crane

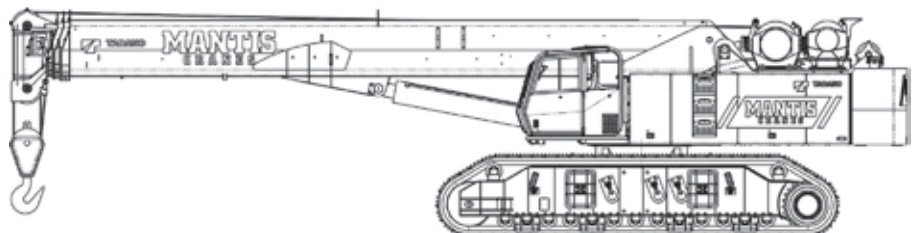

TADANO Ltd., International Division

4-12, Kamezawa 2-chome,
Sumida-Ku, Tokyo 130-0014, Japan

Tel: +81 3 3621 7750

Fax: +81 3 3621 7785

E-mail: tdnihq@tadano.co.jp

www.tadano.co.jp/indexe.html

GTC-400EX

40t Telescopic Boom Crawler Crane

SPECIFICATION SHEET NO. 544-11/11 ISO

GENERAL DATA

CRANE CAPACITY	40t at 3.0m
BOOM	4-section, 10.4 m – 32.0 m
DIMENSION	
Overall Length	13.31 m
Overall Width (tracks extended)	5.59 m
Overall Width (tracks retracted)	3.66 m
Overall Height	3.05 m
MASS	
Gross Vehicle Mass (Standard Equipment Package)	42,590 kg
PERFORMANCE	
Travel Speed	1.3 km/h - 2.1 km/h
Gradeability	68%

CRANE SPECIFICATION

MODEL

GTC-400EX

CAPACITY

40t at 3.0m

BOOM

4-section full power synchronized telescoping boom. Synchronized telescoping system consists of two double acting hydraulic cylinders with load holding valves and extension and retraction cables.

- Retracted Length: 10.4 m
- Extended Length: 32.0 m
- Extension Time: 91 s
- Elevating Angles: -1° to 78°
- Elevating Time: 64 s
- Boom Head: Six, 483 mm diameter cast nylon sheaves on heavy-duty roller bearings

AUXILIARY BOOM HEAD

Quick reeve, single 483 mm diameter high-strength, cast nylon sheave mounted on a heavy-duty roller bearing.

HOOK BLOCKS

- Hook Block: 40t hook block - Four 483 mm diameter sheaves mounted on heavy duty roller bearings with swivel hook and safety latch.
- Headache Ball: 11t ball includes a swivel hook with a safety latch.

WINCHES

Planetary geared two-speed winch includes a bent axis hydraulic motor, multi-disc internal brake, and counterbalance valve. Drum rotation indicator is included (complete winch performance specs on Page 3)

- Main Winch
 - Rope Diameter and Length: 16mm x 183m
 - Single line pull: 69.5 kN (first layer)
 - Single line speed: 75.0 m/min (at the 4th layer)
- Auxiliary Winch
 - Rope Diameter and Length: 16mm x 107m
 - Single line pull: 69.5 kN (first layer)
 - Single line speed: 75.0 m/min (at the 4th layer)

TRAVEL

Each side frame contains a pilot controlled, two-speed track drive with hydraulic axial piston motor and parking brake. Travel system provides skid steering and counter rotation.

- Low travel speed: 1.3 km/h
- High travel speed : 2.1 km/h
- Gradeability (unladen): 68%

COUNTERWEIGHT

6,804kg single piece counterweight can be removed and installed via a pendant attached to the boom

SWING

Gear motor driving a planetary gear reducer with a shaft mounted pinion, external gear shear ball slew bearing bolted to the superstructure and the carbody allows the superstructure to rotate 360°

- Swing Speed: 0 - 2.2 rpm
- Swing Parking Brake: Spring applied failsafe brake with hydraulic release that is controlled from the operators cab
- Swing Service Brake: Hydraulically applied, controlled through foot actuated pedal
- House Lock System: 2-position, manually pinned

LOAD MOMENT INDICATOR

Standard Rated Capacity Limiter and Anti-Two Block system

- Control function shutdown. Audible and visual warnings
- LCD screen provides a continuous display of working boom length, boom angle, working load radius, tip height, parts-of-line (operator set), machine track configuration (operator set), relative load moment, maximum permissible load and actual load.
- Anti-two block weight allows quick reeving of hook blocks.
- Optional 3-color light bar for external indication of load state.

FRAME

The frame is an all-steel, welded structure, precision machined to accept attachment of the boom and swing components.

OPERATORS CAB

Fully-enclosed, air conditioned all-steel modular cab with lockable swinging door, acoustical lining, anti-slip floor and tinted safety glass.

- Rear view cameras are appropriately located as are three remote control work lights.
- Vent window in the rear of the cab.
- Grab bars and steps are located for easy access to the cab.
- Defroster, heater, circulating fan
- 2-speed windshield wiper, top glass wiper
- Six-way adjustable fabric seat with headrest, seat belt
- Dome light
- Dry-chemical fire extinguisher
- Four-way electronic armrest mounted joysticks control swing, main winch, auxiliary winch and boom hoist. Foot pedals control the travel boom extend and swing service brake functions.
- Seat and armrest termination switches immediately disable all hydraulic functions as the operator rises from the seat or lifts the left hand armrest.

Dash instrumentation: tachometer, voltmeter, oil pressure gauge, temperature gauge, hour meter and fuel gauge. Indicators are provided for crane level, load moment, drum rotation, air filter restriction, hydraulic oil temperature and filter restriction, engine oil pressure and temperature.

ENGINE

- Make/ Model: Cummins QSB 6.7
- Type: 6 Cylinder, Water cooled, 4 Cycle
- Aspiration: Turbocharged and Aftercooled
- Max. Output: 194 kW (260 hp) @ 2200 RPM
- Max Torque: 987 Nm (728 Lb-ft) @ 1500 RPM
- Piston Disp: 6.7 liter
- Bore x Stroke: 107mm x 124mm
- Emission Cert: U.S. EPA Tier 3, Euromot Stage IIIA
- Alternator: 130 amp

ELECTRICAL SYSTEM

12 VDC

FUEL SYSTEM

- Capacity: 303 liter
- Filtration: Inline fuel/water separator and engine mounted fuel filter

HYDRAULIC SYSTEM

- Hydraulic Pumps: Two high pressure, variable axial piston pumps with load sense and power limiting control for crane functions. One variable axial piston pump for cooling loop.
- Directional Valves: Multiple pressure and flow compensated valves with integrated relief valves
- Pump output: 583 liter/min @ 2100 RPM engine speed. 330 bar maximum pressure
- Reservoir 1, 136 liter capacity, spin-on filler/breather, sight gauge, cleanout, and sump drain.
- Filtration: 5 micron, full flow tank mounted return filters with electrical clogging indicator. 5 micron pilot oil in-line pressure filter with electrical clogging indicator.
- Diagnostic ports provided for system, load sense, and pilot pressure

SIDE FRAMES

Two welded steel side frames are paired with a track group. The side frames extend and retract hydraulically and are controlled from the cab.

- Track Rollers: Two top and thirteen bottom sealed rollers on each track frame Idler: Oil filled, self lubricating with spring type tensioner
- Track Shoes: 900mm, 3-bar semi grouser

OPTIONAL EQUIPMENT

- Boom Extension: Lattice type, swing away
 - Length: 9.1m
 - Head: Two, 483 mm diameter cast nylon sheaves on heavy-duty roller bearings
 - Max. Lifting Height: 41.2m
- Boom Jib: Lattice type, swing away, stores along boom extension
 - Length: 6.1m - Offset Angles: 15° & 30°
 - Max. Lifting Height: 47.0m
- Track Shoes: 760 mm 3-bar semi grouser
- Auger Ready Package: Includes hoses, fasteners and stowage bracket assembly mounted to the base section of the boom with a flow capability of 130 liter/min
- Complete Auger Package: Adds a two speed auger motor/gear box and one 1,52m kelly bar to the Auger Ready Package.
- Tool Circuit: Provides 23 liter/min and 45 liter/min at 176 bar through a 15,24m twin hose reel with quick disconnect fittings to operate open center tools.
- Free Fall Hoists: All winches are available in controlled free fall configurations.
- 3 Color light bar for external load indication.
- Pole Claw: Heavy duty pole claw with hydraulic open/close and tilt.
- Access Walkways
- Travel lever

MAIN WINCH

Planetary geared two-speed winch includes a bent axis, variable displacement hydraulic motor and a multi-disc internal brake.

Wire Rope: 183 m, 16 mm - FLEX-X 35 Rotation Resistant Line pulls are not based on wire rope strength. Drum rotation indicator is standard.

Rope Layer	Maximum Line Pull (kn)	Full Load Line Speed (m/min.)	Layer (m)	Total (m)
1	69.5	56	32	32
2	62.6	63	35	67
3	56.9	69	39	106
4	52.1	75	42	148
5	48.1	82	46	194
6	44.7	88	50	244

AUXILIARY WINCH

Planetary geared two-speed winch includes a bent axis, variable displacement hydraulic motor and a multi-disc internal brake.

Wire Rope: 107 m 16 mm FLEX-X 35 Rotation Resistant Line pulls are not based on wire rope strength. Drum rotation indicator is standard.

Rope Layer	Maximum Line Pull (kn)	Full Load Line Speed (m/min.)	Layer (m)	Total (m)
1	69.5	56	32	32
2	62.6	63	35	67
3	56.9	69	39	106
4	52.1	75	42	148

MACHINE WEIGHTS

STANDARD CRANE WITH 4 SECTION 32 m BOOM, 1 PIECE COUNTERWEIGHT & 900 mm TRACK SHOES	40,780 kg
Crane Less Counterweights and Track Frames	23,280 kg
Counterweight	6,804 kg
Track Frames, 2 pieces 5,350 kg each	10,700 kg
Auxiliary Winch with Standard Rope	311 kg
Auxiliary Nose Sheave	95 kg
11t Headache Ball	183 kg
40t Hook Block	544 kg

OPTIONAL EQUIPMENT

9,1 m Lattice Extension	771 kg
6,1 m Jib (connects to head of Lattice Extension ONLY)	318 kg
Auger Ready Package	200 kg
Complete Auger Package	690 kg
1,5m Auger Kelly Bar	54 kg
1,8 m Auger Kelly Bar	64 kg

GTC-400EX

40t Telescopic Boom Crawler Crane

SPECIFICATION SHEET NO. 544-11/11 ISO

DIMENSIONS

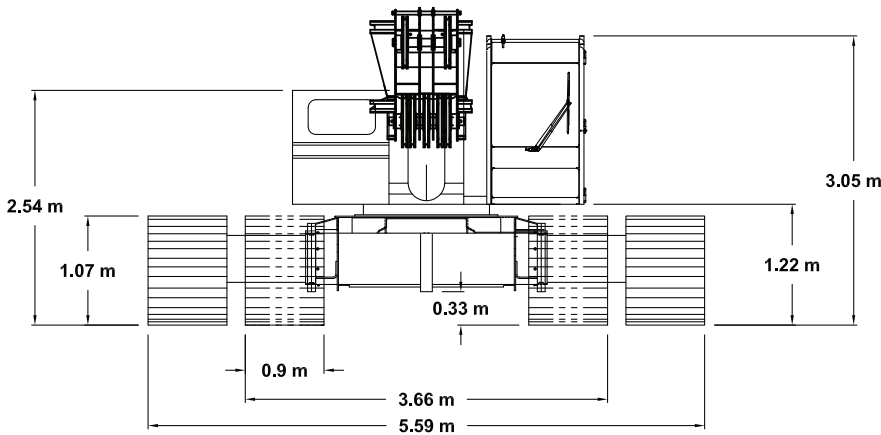
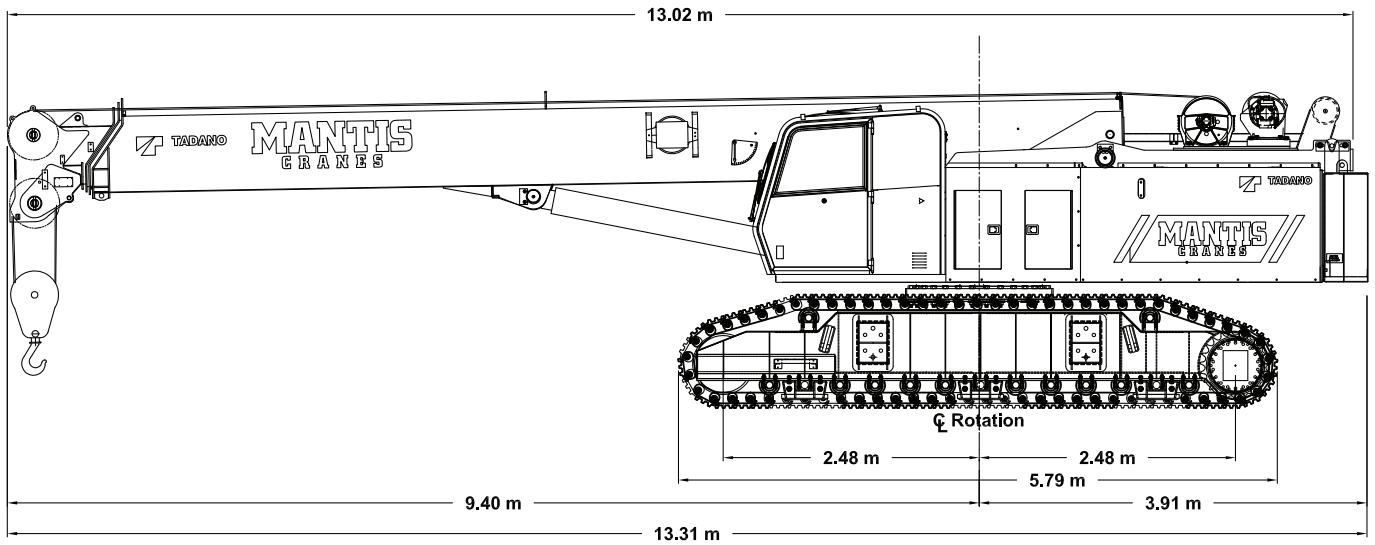

WIDTHS, WEIGHTS, AND GROUND PRESSURES*

Shoe Width	Overall Width		Area	Ground Pressure	Working Weight
	Retracted	Extended			
610 mm	3.35 m	5.22 m	6.04 m ²	0.68 kg/cm ²	40,800 kg
760 mm	3.51 m	5.39 m	7.55 m ²	0.51 kg/cm ²	41,700 kg
900 mm	3.66 m	5.59 m	9.06 m ²	0.47 kg/cm ²	42,590 kg

* Crane equipped with: 34m boom, extension, jib, 45 ton hook block, 12 ton headache ball

32M MAIN BOOM, 9.1M EXTENSION & 6.1M JIB

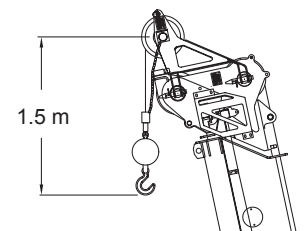
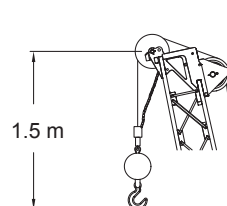
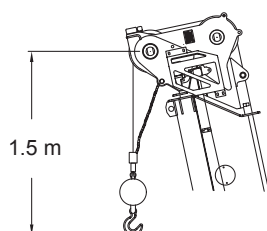
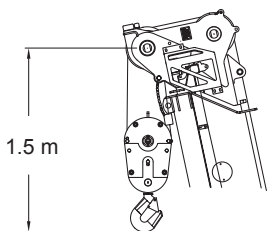
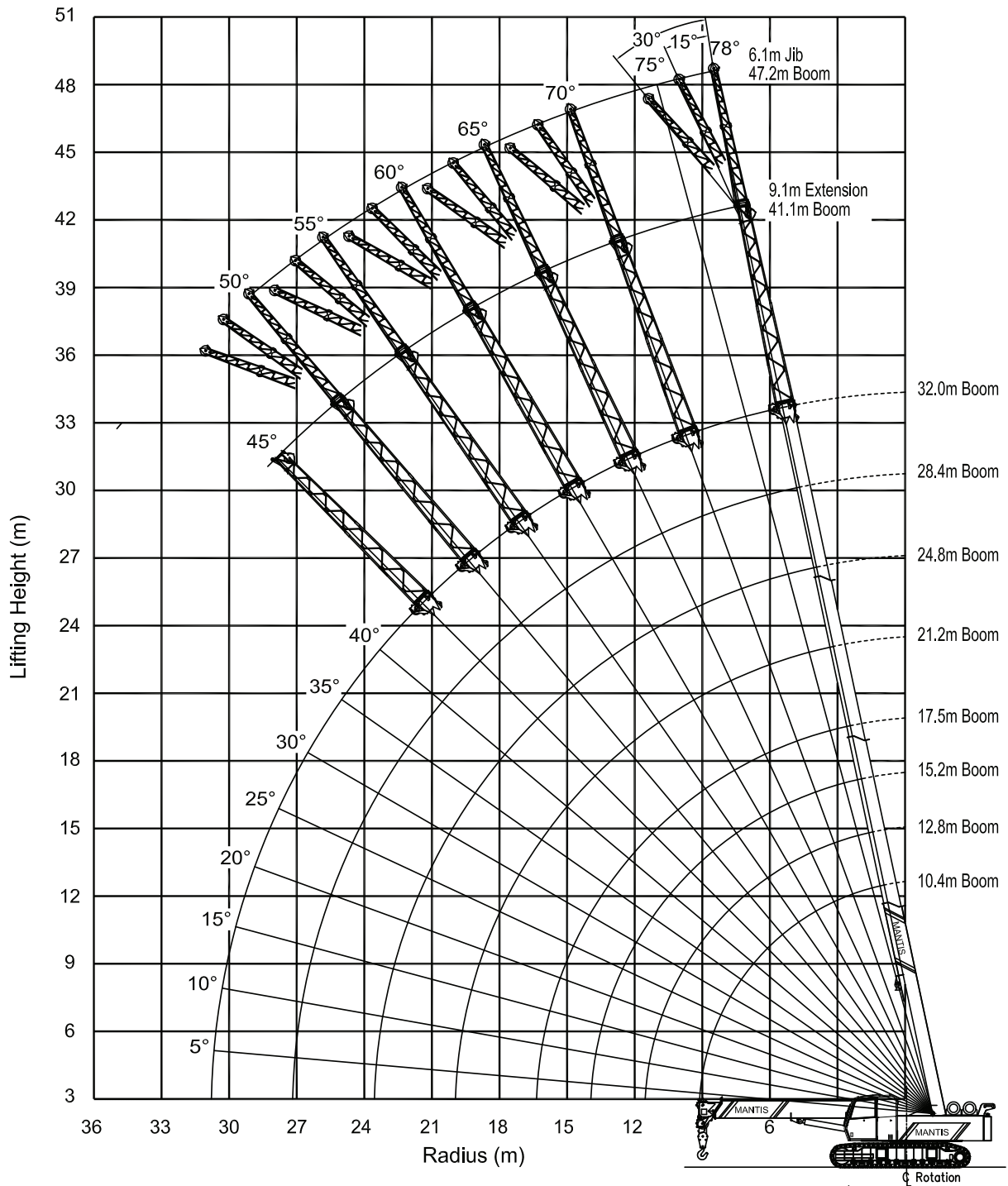

LOAD CHARTS

LIFTING CAPACITIES - LOADS IN METRIC TON

NO TRAVEL – LEVEL 0° TO 1°

MAIN BOOM with TRACKS FULLY EXTENDED									
6.8t COUNTERWEIGHT									
RADIUS (m)	MAIN BOOM LENGTH (m)								RADIUS (m)
	10.4	12.8	15.2	17.6	21.2	24.8	28.4	32.0	
3.0	40.8	36.3	31.8	27.6					3.0
3.5	39.1	35.6	29.7	25.6					3.5
4.0	35.3	33.0	27.8	23.8	21.3				4.0
4.5	30.6	29.5	26.1	22.1	20.5				4.5
5.0	28.7	27.5	25.1	20.9	19.3	16.9			5.0
6.0	24.1	23.5	22.3	18.4	16.8	14.7	13.6		6.0
7.0	17.7	18.2	17.5	16.4	15.0	13.0	12.3	11.2	7.0
8.0	13.6	14.1	14.1	13.6	13.4	11.6	10.9	9.9	8.0
9.0	10.7	11.3	11.2	11.1	11.5	10.5	9.8	8.8	9.0
10.0		9.2	9.2	9.1	9.8	9.6	8.8	7.9	10.0
11.0		7.6	7.6	7.5	8.3	8.4	8.0	7.1	11.0
12.0			6.3	6.2	7.0	7.3	7.3	6.5	12.0
13.0			5.3	5.2	6.0	6.3	6.4	5.9	13.0
14.0				4.4	5.2	5.4	5.6	5.4	14.0
15.0				3.7	4.4	4.7	4.9	4.9	15.0
16.0				3.1	3.8	4.1	4.3	4.3	16.0
17.0					3.3	3.6	3.8	3.8	17.0
18.0					2.8	3.1	3.3	3.3	18.0
19.0					2.4	2.7	2.9	2.9	19.0
20.0						2.4	2.6	2.5	20.0
21.0						2.0	2.2	2.2	21.0
22.0						1.7	1.9	1.9	22.0
23.0						1.5	1.7	1.7	23.0
24.0							1.5	1.4	24.0
25.0							1.2	1.2	25.0
26.0							1.0	1.0	26.0
27.0							0.9	0.8	27.0
28.0								0.7	28.0
29.0								0.5	29.0
30.0								0.4	30.0

LOAD CHARTS

LIFTING CAPACITIES - LOADS IN METRIC TON

NO TRAVEL – LEVEL 3° TO 4°

MAIN BOOM with TRACKS FULLY EXTENDED									
6.8t COUNTERWEIGHT									
RADIUS (m)	MAIN BOOM LENGTH (m)								RADIUS (m)
	10.4	12.8	15.2	17.6	21.2	24.8	28.4	32.0	
3.0	37.6	33.0	28.6	24.3					3.0
3.5	36.0	32.4	26.8	22.6					3.5
4.0	32.5	30.0	25.1	21.0	18.3				4.0
4.5	28.2	26.9	23.5	19.5	17.6				4.5
5.0	26.4	25.0	22.6	18.3	16.6	14.2			5.0
6.0	20.9	19.5	18.0	16.2	14.5	12.3	11.2		6.0
7.0	15.9	15.8	14.6	13.5	12.9	10.9	10.1	9.0	7.0
8.0	12.2	12.7	12.1	11.2	11.1	9.7	8.9	7.9	8.0
9.0	9.6	10.2	10.1	9.4	9.5	8.8	8.0	7.0	9.0
10.0		8.3	8.3	8.0	8.2	7.9	7.2	6.3	10.0
11.0		6.8	6.8	6.7	7.1	6.9	6.6	5.7	11.0
12.0			5.7	5.6	6.2	6.1	6.0	5.2	12.0
13.0			4.8	4.7	5.4	5.4	5.3	4.7	13.0
14.0				4.0	4.6	4.8	4.7	4.4	14.0
15.0				3.3	4.0	4.2	4.2	4.0	15.0
16.0				2.8	3.4	3.7	3.7	3.5	16.0
17.0					3.0	3.2	3.3	3.1	17.0
18.0					2.6	2.8	3.0	2.8	18.0
19.0					2.2	2.4	2.6	2.5	19.0
20.0						2.1	2.3	2.2	20.0
21.0						1.8	2.0	1.9	21.0
22.0						1.6	1.8	1.7	22.0
23.0						1.3	1.5	1.5	23.0
24.0							1.3	1.3	24.0
25.0							1.1	1.1	25.0
26.0							0.9	0.9	26.0
27.0							0.8	0.8	27.0
28.0								0.6	28.0
29.0								0.5	29.0
30.0								0.3	30.0

LOAD CHARTS

LIFTING CAPACITIES - LOADS IN METRIC TON

TRAVEL SPEEDS UP TO 1.4 km/h – LEVEL 0° TO 2°

MAIN BOOM with TRACKS FULLY EXTENDED									
6.8t COUNTERWEIGHT									
RADIUS (m)	MAIN BOOM LENGTH (m)							RADIUS (m)	
	10.4	12.8	15.2	17.6	21.2	24.8	28.4		32.0
3.0	40.8	36.3	31.8	27.6					3.0
3.5	39.1	35.6	29.7	25.6					3.5
4.0	35.3	33.0	27.8	23.8	21.3				4.0
4.5	30.6	29.5	26.1	22.1	20.5				4.5
5.0	28.7	27.5	25.1	20.9	19.3	16.5			5.0
6.0	22.2	21.4	19.9	18.4	16.8	14.4	13.1		6.0
7.0	16.3	16.8	16.0	15.0	14.8	12.8	11.8	10.7	7.0
8.0	12.5	13.0	12.9	12.3	12.3	11.4	10.5	9.4	8.0
9.0	9.9	10.4	10.4	10.3	10.4	10.2	9.4	8.3	9.0
10.0		8.5	8.4	8.4	9.0	8.8	8.5	7.5	10.0
11.0		7.0	7.0	6.9	7.6	7.6	7.5	6.8	11.0
12.0			5.8	5.8	6.5	6.7	6.6	6.2	12.0
13.0			4.9	4.8	5.5	5.8	5.8	5.6	13.0
14.0				4.0	4.7	5.0	5.2	5.0	14.0
15.0				3.4	4.1	4.3	4.5	4.4	15.0
16.0				2.8	3.5	3.8	4.0	3.9	16.0
17.0					3.0	3.3	3.5	3.5	17.0
18.0					2.6	2.9	3.1	3.1	18.0
19.0					2.2	2.5	2.7	2.7	19.0
20.0						2.2	2.4	2.3	20.0
21.0						1.9	2.1	2.0	21.0
22.0						1.6	1.8	1.8	22.0
23.0						1.4	1.6	1.5	23.0
24.0							1.3	1.3	24.0
25.0							1.1	1.1	25.0
26.0							1.0	0.9	26.0
27.0							0.8	0.8	27.0
28.0								0.6	28.0
29.0								0.5	29.0
30.0								0.3	30.0

LOAD CHARTS

LIFTING CAPACITIES - LOADS IN METRIC TON

NO TRAVEL – LEVEL 0° TO 1°

MAIN BOOM with TRACKS FULLY EXTENDED									
0t COUNTERWEIGHT									
RADIUS (m)	MAIN BOOM LENGTH (m)								RADIUS (m)
	10.4	12.8	15.2	17.6	21.2	24.8	28.4	32.0	
3.0	40.8	36.3	31.8	27.6					3.0
3.5	39.1	35.6	29.7	25.6					3.5
4.0	31.7	29.1	27.3	23.8	21.3				4.0
4.5	25.2	23.4	22.3	20.9	19.8				4.5
5.0	20.6	19.3	18.6	17.5	16.8	16.1			5.0
6.0	14.5	13.9	13.6	13.0	12.7	12.3	11.9		6.0
7.0	10.2	10.4	10.4	9.9	9.9	9.7	9.5	9.2	7.0
8.0	7.4	7.6	8.1	7.8	7.9	7.9	7.7	7.6	8.0
9.0	5.4	5.7	6.3	6.2	6.4	6.4	6.4	6.3	9.0
10.0		4.3	4.9	4.9	5.2	5.3	5.3	5.3	10.0
11.0		3.2	3.8	3.8	4.2	4.4	4.4	4.4	11.0
12.0			2.9	3.0	3.4	3.6	3.7	3.7	12.0
13.0			2.2	2.3	2.7	3.0	3.1	3.2	13.0
14.0				1.7	2.1	2.5	2.6	2.7	14.0
15.0				1.2	1.7	2.0	2.1	2.2	15.0
16.0				0.8	1.2	1.6	1.7	1.8	16.0
17.0					0.9	1.2	1.4	1.5	17.0
18.0					0.6	0.9	1.1	1.2	18.0
19.0					0.3	0.6	0.8	1.0	19.0
20.0						0.4	0.6	0.7	20.0
21.0						*	0.4	0.5	21.0
22.0						*	*	0.3	22.0
23.0						*	*	*	23.0
24.0							*	*	24.0
25.0							*	*	25.0
26.0							*	*	26.0
27.0							*	*	27.0
28.0								*	28.0
29.0								*	29.0
30.0								*	30.0

LOAD CHARTS

LIFTING CAPACITIES - LOADS IN METRIC TON

NO TRAVEL – LEVEL 3° TO 4°

MAIN BOOM with TRACKS FULLY EXTENDED									
0t COUNTERWEIGHT									
RADIUS (m)	MAIN BOOM LENGTH (m)								RADIUS (m)
	10.4	12.8	15.2	17.6	21.2	24.8	28.4	32.0	
3.0	37.6	32.9	28.6	24.3					3.0
3.5	30.1	26.1	23.2	20.7					3.5
4.0	24.2	21.3	19.3	17.4	15.8				4.0
4.5	19.9	17.8	16.4	14.9	13.7				4.5
5.0	16.7	15.1	14.1	12.9	12.0	11.1			5.0
6.0	12.3	11.3	10.7	9.9	9.4	8.9	8.4		6.0
7.0	9.1	8.6	8.4	7.8	7.5	7.2	6.9	6.5	7.0
8.0	6.6	6.7	6.7	6.2	6.1	5.9	5.7	5.5	8.0
9.0	4.8	5.1	5.4	5.0	5.0	4.9	4.7	4.6	9.0
10.0		3.9	4.3	4.0	4.1	4.1	4.0	3.9	10.0
11.0		2.9	3.4	3.2	3.3	3.4	3.3	3.3	11.0
12.0			2.6	2.6	2.7	2.8	2.8	2.7	12.0
13.0			2.0	2.0	2.2	2.3	2.3	2.3	13.0
14.0				1.5	1.7	1.9	1.9	1.9	14.0
15.0				1.1	1.3	1.5	1.5	1.6	15.0
16.0				0.7	1.0	1.2	1.2	1.3	16.0
17.0					0.7	0.9	1.0	1.0	17.0
18.0					0.5	0.6	0.7	0.8	18.0
19.0					0.3	0.4	0.5	0.6	19.0
20.0						*	0.3	0.4	20.0
21.0						*	*	*	21.0
22.0						*	*	*	22.0
23.0						*	*	*	23.0
24.0							*	*	24.0
25.0							*	*	25.0
26.0							*	*	26.0
27.0							*	*	27.0
28.0								*	28.0
29.0								*	29.0
30.0								*	30.0

LOAD CHARTS

LIFTING CAPACITIES - LOADS IN METRIC TON

TRAVEL SPEEDS UP TO 1.4 km/h – LEVEL 0° TO 2°

MAIN BOOM with TRACKS FULLY EXTENDED									
0t COUNTERWEIGHT									
RADIUS (m)	MAIN BOOM LENGTH (m)								RADIUS (m)
	10.4	12.8	15.2	17.6	21.2	24.8	28.4	32.0	
3.0	40.8	36.3	31.8	27.6					3.0
3.5	35.1	31.0	28.0	25.2					3.5
4.0	27.5	24.7	22.8	20.8	19.1				4.0
4.5	22.3	20.3	19.0	17.5	16.3				4.5
5.0	18.5	17.0	16.1	15.0	14.1	13.3			5.0
6.0	13.4	12.5	12.1	11.3	10.9	10.4	9.9		6.0
7.0	9.4	9.5	9.3	8.8	8.6	8.4	8.0	7.7	7.0
8.0	6.8	7.0	7.4	6.9	6.9	6.8	6.6	6.4	8.0
9.0	4.9	5.3	5.8	5.6	5.6	5.6	5.5	5.4	9.0
10.0		4.0	4.5	4.5	4.6	4.6	4.6	4.5	10.0
11.0		2.9	3.5	3.5	3.8	3.8	3.8	3.8	11.0
12.0			2.7	2.7	3.1	3.2	3.2	3.2	12.0
13.0			2.0	2.1	2.5	2.6	2.7	2.7	13.0
14.0				1.6	2.0	2.2	2.2	2.3	14.0
15.0				1.1	1.5	1.7	1.8	1.9	15.0
16.0				0.7	1.1	1.4	1.5	1.5	16.0
17.0					0.8	1.1	1.2	1.3	17.0
18.0					0.5	0.8	0.9	1.0	18.0
19.0					0.3	0.5	0.7	0.7	19.0
20.0						0.3	0.4	0.5	20.0
21.0						*	*	0.3	21.0
22.0						*	*	*	22.0
23.0						*	*	*	23.0
24.0							*	*	24.0
25.0							*	*	25.0
26.0							*	*	26.0
27.0							*	*	27.0
28.0								*	28.0
29.0								*	29.0
30.0								*	30.0

LOAD CHARTS

LIFTING CAPACITIES - LOADS IN METRIC TON

NO TRAVEL – LEVEL 0° TO 1°

MAIN BOOM with TRACKS RETRACTED									
6.8t COUNTERWEIGHT									
RADIUS (m)	MAIN BOOM LENGTH (m)								RADIUS (m)
	10.4	12.8	15.2	17.6	21.2	24.8	28.4	32.0	
3.0	35.4	32.3	29.8	27.6					3.0
3.5	28.5	26.2	24.5	22.9					3.5
4.0	23.6	21.9	20.5	19.4	18.5				4.0
4.5	19.9	18.6	17.6	16.6	16.0				4.5
5.0	17.2	16.0	15.2	14.5	14.0	13.5			5.0
6.0	12.7	12.3	11.7	11.2	11.0	10.8	10.5		6.0
7.0	9.7	9.5	9.3	8.9	8.9	8.8	8.6	8.4	7.0
8.0	7.5	7.4	7.5	7.2	7.3	7.2	7.1	7.0	8.0
9.0	5.9	5.9	5.9	5.9	6.0	6.1	6.0	5.9	9.0
10.0		4.7	4.7	4.8	5.0	5.1	5.1	5.0	10.0
11.0		3.7	3.8	3.8	4.2	4.3	4.3	4.3	11.0
12.0			3.0	3.1	3.5	3.6	3.7	3.7	12.0
13.0			2.4	2.5	2.8	3.1	3.1	3.2	13.0
14.0				1.9	2.3	2.6	2.7	2.7	14.0
15.0				1.5	1.9	2.1	2.3	2.3	15.0
16.0				1.1	1.5	1.7	1.9	2.0	16.0
17.0					1.1	1.4	1.6	1.6	17.0
18.0					0.8	1.1	1.3	1.4	18.0
19.0					0.6	0.8	1.0	1.1	19.0
20.0						0.6	0.8	0.9	20.0
21.0						0.4	0.6	0.7	21.0
22.0						*	0.4	0.5	22.0
23.0						*	*	0.3	23.0
24.0							*	*	24.0
25.0							*	*	25.0
26.0							*	*	26.0
27.0							*	*	27.0
28.0								*	28.0
29.0								*	29.0
30.0								*	30.0

LOAD CHARTS

LIFTING CAPACITIES - LOADS IN METRIC TON

TRAVEL SPEEDS UP TO 1.4 km/h – LEVEL 0° TO 2°

MAIN BOOM with TRACKS RETRACTED									
6.8t COUNTERWEIGHT									
RADIUS (m)	MAIN BOOM LENGTH (m)								RADIUS (m)
	10.4	12.8	15.2	17.6	21.2	24.8	28.4	32.0	
3.0	30.6	27.3	24.8	22.7					3.0
3.5	25.1	22.7	20.8	19.2					3.5
4.0	21.1	19.2	17.7	16.5	15.4				4.0
4.5	18.0	16.5	15.3	14.3	13.6				4.5
5.0	15.7	14.4	13.4	12.6	12.0	11.4			5.0
6.0	11.7	11.2	10.5	9.9	9.6	9.2	8.9		6.0
7.0	8.9	8.8	8.4	7.9	7.8	7.6	7.3	7.1	7.0
8.0	6.9	6.8	6.8	6.5	6.4	6.3	6.2	6.0	8.0
9.0	5.4	5.4	5.4	5.3	5.4	5.3	5.2	5.1	9.0
10.0		4.3	4.4	4.4	4.5	4.5	4.4	4.3	10.0
11.0		3.4	3.5	3.5	3.7	3.8	3.8	3.7	11.0
12.0			2.8	2.8	3.1	3.2	3.2	3.2	12.0
13.0			2.2	2.3	2.6	2.7	2.7	2.7	13.0
14.0				1.8	2.1	2.3	2.3	2.3	14.0
15.0				1.4	1.7	1.9	1.9	2.0	15.0
16.0				1.0	1.4	1.5	1.6	1.7	16.0
17.0					1.0	1.2	1.3	1.4	17.0
18.0					0.8	1.0	1.1	1.1	18.0
19.0					0.5	0.7	0.8	0.9	19.0
20.0						0.5	0.6	0.7	20.0
21.0						0.3	0.4	0.5	21.0
22.0						*	0.3	0.3	22.0
23.0						*	*	*	23.0
24.0							*	*	24.0
25.0							*	*	25.0
26.0							*	*	26.0
27.0							*	*	27.0
28.0								*	28.0
29.0								*	29.0
30.0								*	30.0

LOAD CHARTS

LIFTING CAPACITIES - LOADS IN METRIC TON

NO TRAVEL – LEVEL 0° TO 1°

AUXILIARY NOSE SHEAVE with TRACKS RETRACTED									
6.8t COUNTERWEIGHT									
RADIUS (m)	MAIN BOOM LENGTH (m)								RADIUS (m)
	10.4	12.8	15.2	17.6	21.2	24.8	28.4	32.0	
3.0	5.0	5.0	5.0	5.0					3.0
3.5	5.0	5.0	5.0	5.0					3.5
4.0	5.0	5.0	5.0	5.0	5.0				4.0
4.5	5.0	5.0	5.0	5.0	5.0				4.5
5.0	5.0	5.0	5.0	5.0	5.0	5.0			5.0
6.0	5.0	5.0	5.0	5.0	5.0	5.0	5.0		6.0
7.0	5.0	5.0	5.0	5.0	5.0	5.0	5.0	5.0	7.0
8.0	5.0	5.0	5.0	5.0	5.0	5.0	5.0	5.0	8.0
9.0	5.0	5.0	5.0	5.0	5.0	5.0	5.0	5.0	9.0
10.0		4.6	4.6	4.7	4.9	5.0	5.0	4.9	10.0
11.0		3.6	3.7	3.7	4.1	4.2	4.2	4.2	11.0
12.0			2.9	3.0	3.4	3.5	3.6	3.6	12.0
13.0			2.3	2.4	2.7	3.0	3.0	3.1	13.0
14.0				1.8	2.2	2.5	2.6	2.6	14.0
15.0				1.4	1.8	2.0	2.2	2.2	15.0
16.0				1.0	1.4	1.6	1.8	1.9	16.0
17.0					1.0	1.3	1.5	1.5	17.0
18.0					0.7	1.0	1.2	1.3	18.0
19.0					0.5	0.7	0.9	1.0	19.0
20.0						0.5	0.7	0.8	20.0
21.0						0.3	0.5	0.6	21.0
22.0						*	0.3	0.4	22.0
23.0							*	0.2	23.0
24.0							*	*	24.0
25.0							*	*	25.0
26.0							*	*	26.0
27.0							*	*	27.0
28.0								*	28.0
29.0								*	29.0
30.0								*	30.0

LOAD CHARTS

LIFTING CAPACITIES - LOADS IN METRIC TON

NO TRAVEL – LEVEL 0° TO 2°

9.1m EXTENSION & 6.1m JIB with TRACKS FULLY EXTENDED						
6.8t COUNTERWEIGHT						
9.1m EXTENSION			6.1m JIB			
Boom Angle	Total Boom Length		Jib Offset Angles			Boom Angle
	19.5m to 32.0m	> 32.0m	0°	15°	30°	
78°	8.2‡	6.4‡	3.0	1.8	1.0	78°
75°	6.2‡	5.6‡	2.9	1.8	1.0	75°
72°	5.2‡	4.5‡	2.5	1.6	0.9	72°
70°	4.6‡	4.1‡	2.3	1.5	0.9	70°
68°	4.0‡	3.6	2.1	1.4	0.8	68°
65°	3.6	3.4	1.9	1.3	0.8	65°
62°	3.3	2.7	1.8	1.2	0.8	62°
60°	3.0	2.0	1.6	1.1	0.8	60°
58°	2.8	1.8	1.5	0.9	0.6	58°
55°	2.6	1.4	1.2	0.6	0.5	55°
52°	2.4	1.1	0.9	0.3	0.2	52°
50°	2.3	0.9	0.6	*	*	50°
48°	2.2	0.7				48°
45°	2.1	0.5				45°

‡ 2 parts of line reeving required

GTC-400EX

40t Telescopic Boom Crawler Crane

SPECIFICATION SHEET NO. 544-11/11 ISO

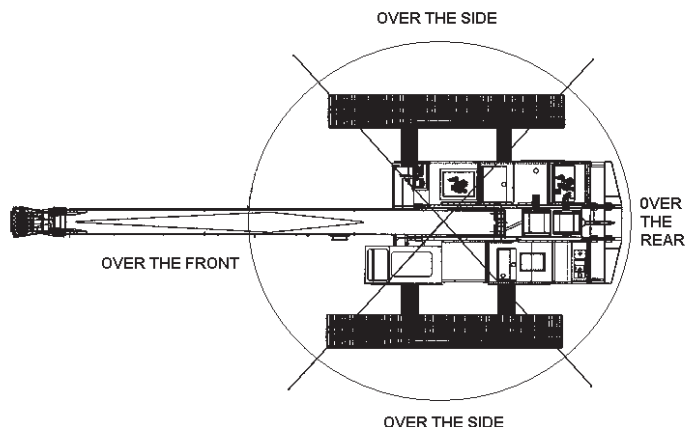

GTC-400EX				
WIRE ROPE LINE PULL CAPACITIES				
PARTS OF LINE	MAIN WINCH (kN)	AUX WINCH (kN)	PARTS OF LINE	MAIN WINCH (kN)
1	52.3	52.3	5	261.8
2	104.7	104.7	6	314.2
3	157.1	N/A	7	366.5
4	209.4	N/A	8	418.9

19mm diameter wire rope, Flex-X 35 Rotation Resistant

PLEASE READ, UNDERSTAND, AND FOLLOW THE MANUALS FURNISHED WITH THE CRANE (OPERATORS AND SAFETY) AS WELL AS THE CAPACITY LIMITATIONS AND GENERAL CONDITIONS LISTED BELOW PRIOR TO OPERATION OF THE CRANE. FAILURE TO DO SO MAY RESULT IN AN ACCIDENT.

This **MANTIS CRANE** as manufactured by **Tadano Mantis Corporation** meets the requirements of **ISO4301/2 or 4308/2**. Structure and stability have been tested in accordance with this standard. Lifting capacities as determined by boom length, angle or radius, apply only to machines as originally equipped by manufacturer and in a properly maintained condition. Capacities given are maximum covered by the manufacturers warranty and are based on a freely suspended load with **NO** allowance for factors as out-of-level operation (beyond the limits specified on the charts), supporting surface conditions, hazardous surroundings, experience of personnel, etc. The operator shall establish practical working loads based on prevailing operating conditions, such as, but not limited to the above. If your application varies from the conditions as set forth in ISO 4301/2 or ISO4308/2 consult your Tadano Mantis Service department for recommendations on adjustments to the rated capacity of the crane.

When making lifts where capacities may be within a zone limited by structural strength, the operator shall determine that the weight of the load is known within plus or minus (+/-) ten percent (10%) before making lift. **DO NOT** lift load or extend boom without counterweight in place. Deductions from rated capacities must be made for the weight of the hook block, hook/ball, slings, spreader bar, or other suspended equipment.

Side pull on boom is extremely dangerous and must be avoided.

DO NOT exceed manufacturers maximum specified reeving.

DO NOT use this chart if wind speed exceeds 36 km/h. Consult the manufacturer for specialized load ratings.

Load radius is defined as the horizontal distance from the axis of rotation (with no load) to the center of the lifting device after load is applied. Boom angle is the included angle between the longitudinal axis of the boom base section and the Horizontal axis, after lifting load. The boom angle before lifting should be slightly greater than desired to account for boom deflection.

Boom angle/boom length relationships given are an approximation of the resulted load radius, which should be an accurate measurement. Boom height dimensions are measured from ground to center of lower boom head sheave.

It is permissible to attempt to telescope boom with a load within the limits of rated capacities. However, boom angle system hydraulic pressure, and/or boom lubrication may affect operation.

It is permissible to travel with loads within the rated capacity of the crane. Travel speeds should be greatly reduced to reflect terrain limitations and minimize dynamic loads applied to the crane structure.

Load moment indicating and anti-two block systems are operator aids and must never be used in lieu of job site lift planning calculations by the operator which must take into account ground conditions, weather and all other environmental factors prevailing at the time of the lift. Prices and specifications are subject to change at any time without prior notice and are for factory installation at the time of original manufacture. Illustrations and photographs may show optional equipment. Supercedes all previous issues. Please see www.mantiscranes.com for most current information.

TADANO MANTIS CORPORATION

1705 Columbia Avenue • Franklin, TN 37064 USA • Toll-Free: 1-800-272-3325 • Fax: 615-790-6803 • mantiscranes.com

TADANO Ltd., International Division

4-12, Kamezawa 2-chome,
Sumida-Ku, Tokyo 130-0014, Japan

Tel: +81 3 3621 7750

Fax: +81 3 3621 7785

E-mail: tdnihq@tadano.co.jp

www.tadano.co.jp/indexe.html