

# **P&H**® *Century 108i*

## **Industrial Crane (Carry Deck) 8 -1/2 tons (7.5 tonnes) Lifting Capacity 9 tons (8 tonnes) Total Deck Capacity**

- Pick and carry capacity of 8.5 tons.
- Versatile and agile, it's designed specifically for industrial in-plant operation. This compact crane, with its low profile, fits through almost all overhead door openings.
- All-around visibility gives you added confidence in pick and carry operations.
- Electronic load moment indicator (LMI) is standard equipment. LMI gives you precise crane information under any load conditions.
- Load capacity of the CN 108i Industrial Crane is among the highest in the industry.
- Carry deck capacity of 12,000 lbs. adds to this crane's utility.
- **PRIDE Plus** **DDM P&H** The Pride Plus warranty . . . the most comprehensive warranty in the business. Our standard warranty covers the entire crane for 12 months or 2000 hours of operation, whichever comes first. Major weldment structures are covered for 5 years or 10,000 hours of operation.



[dzwigi24.pl](http://dzwigi24.pl)

## **Specifications**

# Specifications

This P&H crane meets the requirements of ANSI B30.5c-1987. Boom Structure (boom and extension) has been tested per SAE J1063, machine stability tested per SAE J765.



**Boom:** All boom sections are of full depth rectangular four plate construction, with adjustable slider pads on top, bottom and sides. All powered sections are single lever controlled. Block type semi-fixed telescope cylinder mounts provide ample capacity to telescope loads.

Extension mechanism consists of one hydraulically powered cylinder with holding valve.

Boom point contains one idler sheave and one load sheave, bronze bushing mounted. Sheaves are 10.12" (257.2 mm) pitch diameter.

**Standard Boom:** 22' (6.7 m) three (3) section powered boom, 11' (3.35 m) retracted length, 22' (6.7 m) extended length, consisting of one base section, one mid section, and one outer section with boom point. Both sections are powered by one piggy-back hydraulic cylinder.

**Boom Hoist:** One 7 in. (178 mm) bore x 21.75 in. (552 mm) stroke cylinder, double-acting. Hydraulically powered raising and lowering with holding valve.

**Boom Telescope:** One piggy-back 3.5 in. (89 mm) I.D. - double-acting cylinder for powered section. Hydraulically powered extending and retracting with holding valve.

**Counterweight:** 550 lbs. (250 kg)

## BOOM OPTIONS

**25 ft. (7.62 m) three (3) section powered boom:** 12 ft. (3.65 m) retracted length, 25 ft. (7.62 m) extended length, consisting of one base section, one hydraulically powered mid section, and one cable powered outer section with boom point.

**32 ft. (9.75 m) four (4) section boom:** Three sections powered and one 7 ft. (2.13 m) manual pull out section. Boom is based on the 25 ft. (7.62 m) boom above with manual pull out section.

**10 ft. (3 m) extension:** Swing around tapered structure with single 10.12 in. (25.7cm) P.D. phenolic boom point sheave with bronze bushing. Easily installed from ground by swinging from its stored position on side of boom base. Tapered pins connect to boom point. Includes anti-two-block material and stowage material.

**10 ft. (3 m) offsettable extension:** Swing around structure as per the 10 ft. (3.0 m) extension above, but with pivoting link system which allows it to be offset to 15°, 30° and 45° for extending reach of the boom. Includes anti-two-block material and stowage material.

**Searcher Hook:** Rhino style hook on boom tip, for use where headroom is limited.

## Cable Spooling Device.

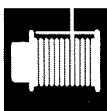

**Winch:** Single speed, mounted on rear of upper frame. Planetary gearing with equal speed power raising and lowering. Infinitely variable controlled speed. Spring applied, hydraulically released load holding multiple disc brake is automatic. Complete with 90 ft. (27.4 m)

wire rope.

**Drum:** 10.31 in. (262 mm) P.D. X 13.5 in. (343mm) wide with 13.75 in. (349mm) diameter flanges.

**Wire Rope (Standard):** 9/16 in. (14mm) dia. 6x37 extra improved plow steel, with 7x7 I.W.R.C. 132 ft. (40.3 m) 2 layers.

**Drum Capacity:** 132 ft. (40.3 m) 2 layers.

**Line Pull (Max.):** 12,000 lbs. (5443 kg) 1st layer.

**Line Pull (Permissible) (based on strength of wire rope):** 9600 lbs. (4355kg) 6x37 cable.

**Line Speed Up (max.):** 115 fpm (35 m/m) 2nd layer.

## HOISTING OPTIONS

**Spin Resistant Wire Rope:** 5/8 in. (16 mm) x 110 ft. (33.5 m) Dynopac 18 extra improved plow steel. Permissible line pull with 5 to 1 safety factor is 8400 lbs. (3810 kg).

**8.5 Ton (7.7 tonnes) Hook Block:** One sheave with swivel and safety latch.

**5 Ton (4.5 tonnes) Weighted Hook:** With swivel.

**Hydraulic System:** System utilizes one tandem gear type pump. Total flow is 40 gpm (152 lpm). All hydraulic oil is filtered to 10 microns on return to the reservoir. Maximum pressure drop of return filter with clean element and oil at normal operating temperature is 25% of by-pass setting to assure minimum fluid resistance and power loss while protecting seals in cylinders, valves and motors. The reservoir has a 50 gallon (189 l) capacity. Pumps, valves, cylinders and motors are readily accessible and easy to service. Control valves are four-way, three-position type with low effort spools and pilot-operated relief valves for quick, smooth response. Control levers are connected direct to the directional valves.



**Swing Unit:** Hydraulic motor driving through gear reducer to pinion gear, 360° continuous rotation to 2 rpm.

**Swing Gear:** External cut spur gear with safety-dust cover.

**Swing Brake:** Worm gear drive has self-locking ratio. Swing is locked when hydraulic power is removed.

**Fastening to Lower:** Single row ball bearing integral with swing gear bolted to carrier frame and to rotating frame. Bearing is protected from dust by labyrinth seal.

**Rotary Manifold:** Sealed rotary swivel for hydraulic hose connections between rotating upper and carrier. Easily removable for servicing. Electrical collector is mounted on bottom of hydraulic swivel.



**Carrier:** 4 x 2 x 2 (front wheel drive, rear wheel steer). Carry deck is 55 square feet (5 square meters) in size with 12,000 pounds (5443 kg) of capacity.

**Carrier Options:** Front wheel steer in addition to the rear. (4 x 2 x 4). Front fold-down carry platform with 6000 pounds (2722 kg) capacity. Bumper winch. Front or rear pintle hooks.

**Frame:** All welded unitized construction assures rigidity and permanent alignment of swing bearing and rotating upper machinery.



**Hydraulic Outriggers:** Four (4) independent arm-type assemblies that hydraulically pivot diagonally from deck frame to form a stable working platform. Outriggers may be set in either vertical or diagonal position. Capacity charts are provided for both positions. Outrigger floats provide 80 sq. in. (516 sq. cm.) per float. Extended spread is 11 ft. 4 in. (3.45 m) from C/L to C/L of floats. Retracted within carrier width of 6 ft. 6 in. (1.98 m).



**Operator's Cab:** Low profile, easy entry environmental cab with side entry door of steel construction, left side mounted between front and rear axles. Large tinted safety glass windows are used throughout, providing excellent view of work areas. Sliding side window opens for ventilation. Operator's seat is vinyl covered and adjustable with a safety belt.

**Cab Equipment:** Cab contains all roading and crane function controls. Front console includes gauges for engine water temperature, engine oil pressure, voltmeter and fuel. Also includes hour-meter, load moment indicator, electric anti-two-block warning indicator, audio back-up alarm, windshield wiper, fire extinguisher, electric horn, hot water heater and defroster, and tachometer. Rear view mirrors are side deck mounted.



**Steering:** Rear axle pressure compensated hydrostatic power steering is standard. Front axle power steering is optional. Two wheel, four wheel and crab steer mode selection is controlled by three-position switch located in cab. All steering is controlled by the steering wheel.

**Front axle:** Rigid mounted drive axle with no spin differential and planetary in hubs. Steer/drive is optional.

**Rear Axle:** Non-powered with power steering. Axle is pivot mounted. Oscillation has 2 in. (5 cm) vertical movement.

**Service Brakes:** Hydraulic assisted dual circuit brakes on all four wheels. Wet disc on front axle and dry disc on rear axle actuated by foot pedal in cab.

**Parking Brake:** Hydraulically released spring applied 10 in. (25.4 cm) disc brake on output yoke of transmission.

**Tires:** Standard: 10:00x15-18PR tube type. Highway tread.  
Optional: 10:00R15-16PR tube type. Mine lug.  
Optional spare tire and rim available.

**Miscellaneous Equipment (Standard):** Sliding engine hood, tow lugs, highway lights.



**Power Plant:**

	<u>Standard</u>	<u>Optional</u>
<b>Make:</b>	Cummins	Continental
<b>Model:</b>	4B3.9	TM27
<b>Type:</b>	Diesel	Propane
<b>Cylinders:</b>	Four (4)	Four (4)
<b>Bore x Stroke:</b>	4.02 x 4.72 in. (102 x 120 mm)	3.58 x 4.0 in. (91mm x 103.2mm)
<b>Displacement:</b>	239.3 cu.in. 3.92 liters	164.7 cu. in. 2.7 liters
<b>Cycles:</b>	Four (4)	Four(4)
<b>Air Induction:</b>	Naturally aspirated	Naturally aspirated
<b>Alternator:</b>	63 amp	63 amp
<b>Gross HP @ rpm:</b>	76 @ 2500	58
<b>Kilowatts @ rpm:</b>	56.7 @ 2500	43.3

**Accessories:**

**Electrical:** System is 12 volt, negative ground. Wire harnesses have protective braided nylon covering and are individually clamped to frame-work. Environmentally-sealed toggle-type switches and harness connectors are used.

**Battery:** 320 cold cranking amps at 0° F

**Fuel Tank:** 20 gal. (75.6 l)

**Air Cleaner:** Single stage dry - replaceable element.

**Lube Oil Filter:** Replaceable element. Full-flow.

**Fuel Filter:** Spin-on replaceable element.



**Transmission:** Shuttle operation. Constant mesh, dual multi-disc clutch packs provide either forward or reverse. Clutches are modulated for smooth directional change. Four (4) speed, full synchromesh transmission with "H" gate shift pattern. Button shift on shift lever releases clutch for changing gears. Shuttle control is steering column mounted. Speed range lever is side mounted.

**Transmission Option:** Fully sequential power shift with four speeds forward and reverse. Electrically controlled and operated gearshift with neutral safety start.



**Performance:** Based on engine at full load rpm, 15,000 lb. (6800 kg) gross vehicle weight, 10:00 x 15 tires, 22' (6.7 m) boom, 550 lbs. (250 kg) counterweight and good surface road. Maximum grade at 1 mph (.62 kph) is 96% (theoretical).

**1st gear** 4 mph (6 kmph)  
**2nd gear** 8 mph (13 kmph)  
**3rd gear** 12 mph (19 kmph)  
**4th gear** 21 mph (34 kmph)

**Miscellaneous Equipment (Optional):** Roof window wiper, amber rotating beacon, floodlights, two-battery start system, rear steer indicator with light, engine condition warning system, and windshield washer.

**Note:** Capacity charts and related lifting data can be found in a separate publication.

[dzwigi24.pl](http://dzwigi24.pl)

# General Dimensions

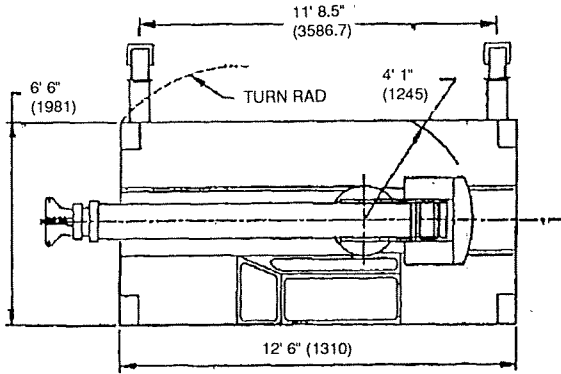

CRANE	TURNING RAD.
4 WHL STEER	12'-3" (3.7m)
2WHL STEER	18'-5" (18.4m)

CRANE	X	Y
12-25 FT. BOOM	9' - 11.25" (3 m)	15' - 8.25" (4.8 m)
10'-3" - 22' BOOM	8' - 0.75" (2.5 m)	13' - 9.75" (4.2 m)

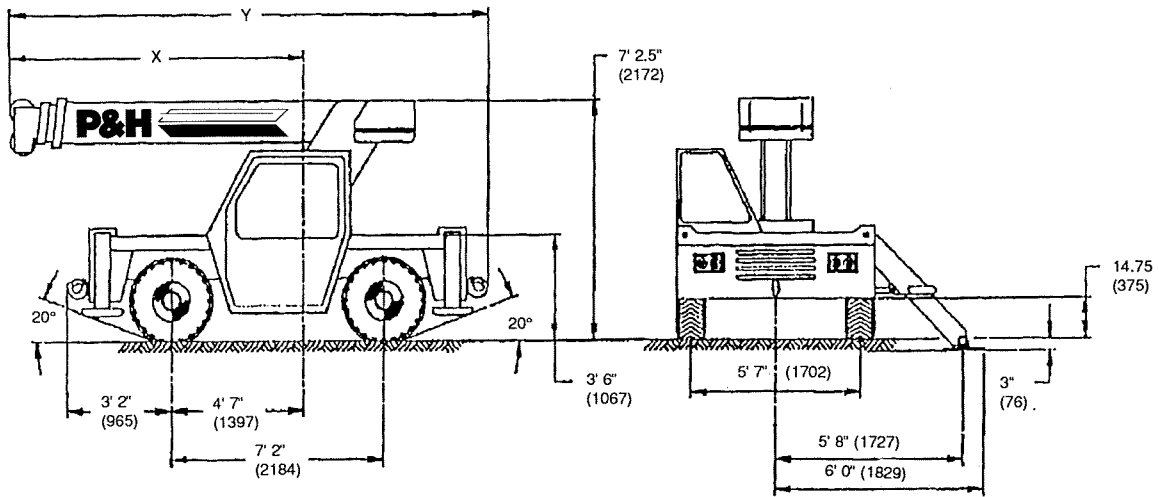

NOTE: All designs, specifications and components of the equipment described above are subject to change at the manufacturer's sole discretion at any time and without advance notice. The individual load charts and related lifting data on each crane must be understood and govern operation of the crane. Data published herein is informational in nature and shall not be construed to warrant suitability of the machine for any particular purpose as performance may vary with conditions encountered. The only warranty applicable is our standard warranty for this machine.



**PPM CRANES, INC**  
 Manufacturer of P&H Mobile Cranes  
 P.O. Box 260002  
 Conway, SC 29526-2602  
 USA  
 Phone: 1-803-349-6900